



KIWANIS ALL WHEEL PARK

WORKSHOP #2 & ONLINE SURVEY #2 FEEDBACK SUMMARY REPORT



NOVEMBER 2023



**KIWANIS ALL WHEEL PARK
WORKSHOP #2 & ONLINE SURVEY #2
FEEDBACK SUMMARY REPORT**

NORTH BAY ALL WHEEL PARK



**Design
Workshop #2**
Thurs. Nov. 16 6-8pm
North Bay Museum
100 Ferguson Street
North Bay, ON

**Online
Survey #2**
opens: Nov. 16
closes: Nov. 30

Learn more about this exciting community project.
Meet the design team. Complete the survey.
Provide Feedback on Preliminary Design Directions.





KIWANIS ALL WHEEL PARK WORKSHOP #2 & ONLINE SURVEY #2 FEEDBACK SUMMARY REPORT

TO: David Jackowski, P.Eng.
Project Manager | Special Projects Operations and Infrastructure | City of North Bay

DATE: December 1, 2023

RE: KIWANIS ALL WHEEL PARK
WORKSHOP #2 & DESIGN SURVEY #2 - FEEDBACK SUMMARY REPORT

Dear David,

The following is a summary of the feedback gathered at the In-Person Workshop #2, held in North Bay on November 16, 2023, as well as Online Survey #2 prepared by New Line Skateparks Inc. and hosted on Google Forms from November 16-30. Overall, the In-Person Workshop collected a total of (28) Participant Feedback Forms and the Online Survey #2 collected a total of (1170) responses. Approx. (91%) of total responses were categorized as “Active Park Users”. This second round of Community Feedback shows a very high level of community interest in the project and provides valuable feedback for the design team to consider in developing the Preferred Design.

PART ONE: DEMOGRAPHIC QUESTIONS

Question 1: Where do you live?

- **70.4%** in North Bay
- 29.6% outside North Bay

The majority of responses came from residents living in North Bay.

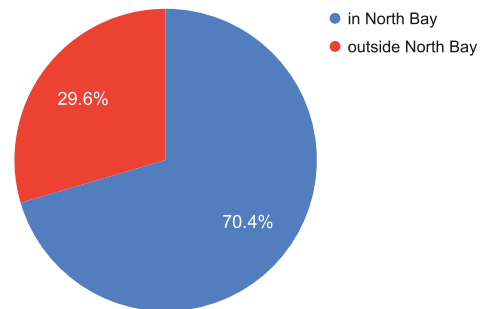

Question 2: How old are you?

- **32.7%** 21-30 years old
- 27.5% 31-40 years old
- 13.7% 41-50 years old
- 11.1% 0-10 years old
- 4.3% 50+ years old

A wide range of age groups is represented. The largest representation was from participants in the 21-30 year old category.

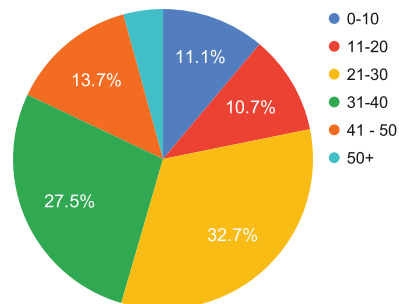

PART TWO: PARTICIPATION

Question 3: I am primarily interested in the project because I am ...

- 27.2% a skateboarder
- 22.4% a mountain biker
- 18.5% a BMX rider
- 13.9% a scooter rider
- 9.2% a rollerskater / blader

The majority of responses (27.2%) came from skateboarders. Mountain bikers have the second-highest representation among the Active User Groups.

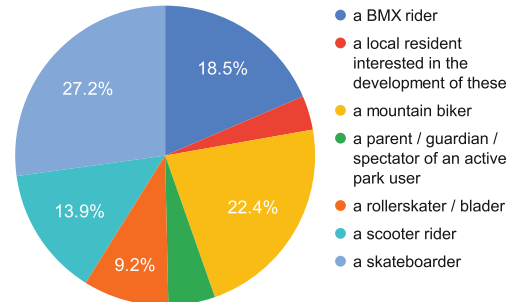

Question 4: How would you describe your Skateboarding / Riding ability?

- 54.1% Intermediate
- 24.9% Advanced
- 12.3% Beginner
- 8.7% I don't skate or ride

Our goal is to create a well-rounded design with a wide range of ability levels in mind.

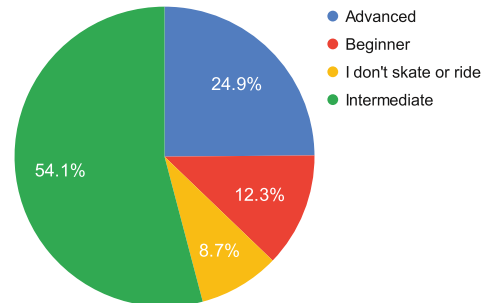

Question 5: How often do you skate / ride?

- 57.1% 3+ Days a week
- 25.4% 1-2 times a week
- 9.1% I don't skate or ride
- 8.5% 1-2 times a month

The majority of responses (57.1%) show a high rate of participation (3+ days a week) for the Active Park Users.

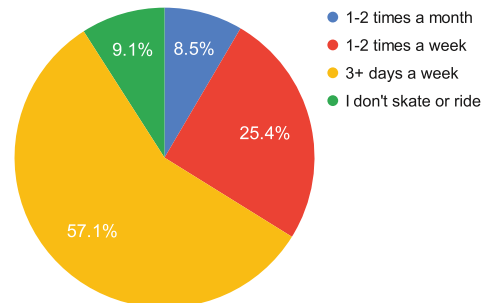

Question 6: What part of the All Wheel Park interests you the most?

- 53.7% Skatepark
- 46.3% Pump Track

The majority of "Active Park Users" are primarily interested in the Skatepark (53.7%).

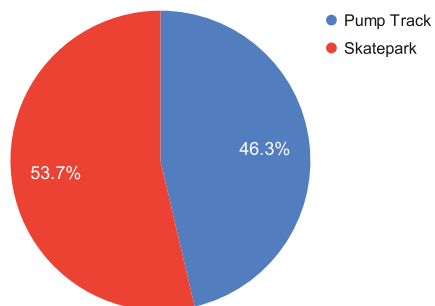

NOTE: (1068) out of (1170) total responses (91.28%) were categorized as "Active Park Users". Only "Active Park Users" were then able to respond to questions re: Design Direction Preferences.

PART THREE: PUMP TRACK DESIGN DIRECTION PREFERENCES

Question 7: Select your Preferred Pump Track Design Direction.

- **90.4%** Design Direction #1
- 7.8% Design Direction #3
- 1.8% Design Direction #2

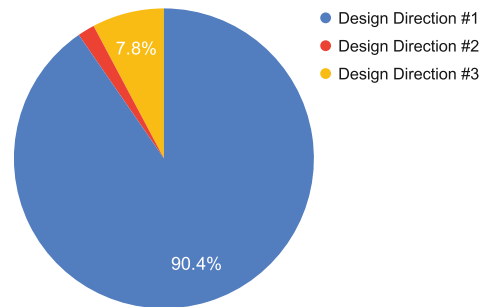

(90%) of those who responded “Pump Track” to question 6 selected Design Direction #1 as their preferred Pump Track Design Direction.

Question 8: “Why” people selected Pump Track Design Direction #1 as their preferred option:

- **Diverse Skill Level Accommodation:** Appreciation for the inclusion of both beginner and intermediate skill levels in the design. Positive reception of the layout allowing for a variety of abilities, catering to beginner and advanced riders.
- **Design & Layout Preferences:** Preference for the layout of Design #1, particularly for its flow and the potential for future expansion. The design is favoured for its ability to accommodate more users and facilitate growth in skills. Specific liking for the two separate track areas catering to different skill levels.
- **Flow & Challenge:** The layout is appreciated for providing a good mixture of turns, longer straight sections, and rhythm sections, offering a challenging experience. Positive remarks on the flow of the design, with the potential for transfers between lines.
- **Jump Line Opportunities:** A notable preference for more places to put a jump line, indicating a desire for more dynamic and challenging features. Suggestions for adding a solid jump line in the main pump track for enhanced excitement and skill development.
- **Aesthetics & Overall Appeal:** General consensus that Design #1 looks visually appealing and inviting. The design is perceived as the nicest in terms of aesthetics and practicality.
- **Combination with Skatepark:** A strong preference for Design #1 when considered in combination with the skatepark layout. The design is seen as offering the best flow and features for both the pump track and the skatepark.
- **Community Engagement:** Enthusiasm about the project, with anticipation for the new pump track and skatepark. Expressions of willingness to travel specifically for this pump track, highlighting its appeal beyond the local community.

PART FOUR: SKATEPARK DESIGN DIRECTION PREFERENCES

Question 11: Select your Preferred Skatepark Design Direction.

- **69.8%** Design Direction #1
- 26.2% Design Direction #3
- 4.1% Design Direction #2

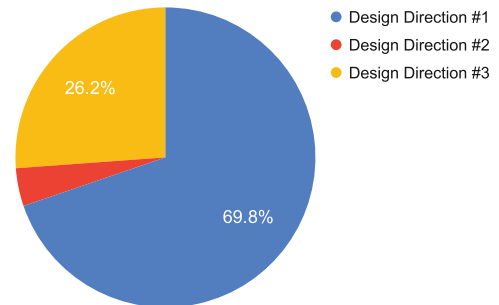

(70%) of those who responded “Skatepark” to question 6 selected Design Direction #1 as their preferred Skatepark Design Direction.

Question 12: “Why” people selected Skatepark Design Direction #1 as their preferred option:

- **Overall Design & Flow:** A strong preference for the layout and flow of Design #1, with many appreciating its spaciousness and ability to accommodate multiple riders simultaneously. Positive remarks on the design’s cohesiveness, allowing for seamless transitions between obstacles and uninterrupted skating.
- **Variety of Skateable Options:** Enthusiasm for the variety of skateable features in Design #1, including rails, stairs, and elevated plaza areas. Specific mentions of the need for a diverse range of obstacles, from stairs and rails to more unique features, catering to different skill levels.
- **Focus on Skatepark over Pump Track:** A notable number of responses indicated a preference for a larger skatepark area as opposed to the pump track, suggesting a desire for more space dedicated to skateboarding. Some responses explicitly stated a lack of interest in the pump track, emphasizing the importance of the skatepark features.
- **Beginner-Friendly & Progressive Design:** The design is seen as favorable for beginners, with features that allow for skill progression and cater to a wide range of users. Suggestions for the skatepark to be tailored more towards beginners, with the belief that intermediate skaters can adapt to any park.
- **Aesthetic Appeal & User Experience:** Positive feedback on the aesthetic appeal of Design #1, with some finding it the most visually attractive and fun. Comments on the importance of aesthetics and the impact on the overall user experience.
- **Community Engagement & Anticipation:** Expressions of excitement and anticipation for the new skatepark, with many looking forward to its completion. Participants showing support for the project and its potential positive impact on the local community.



KIWANIS ALL WHEEL PARK WORKSHOP #2 & ONLINE SURVEY #2 FEEDBACK SUMMARY REPORT

PART FIVE: ADDITIONAL INFORMATION

Question 15: Do you have any questions or comments related to the Kiwanis All Wheel Park?

- **Community Enthusiasm & Anticipation:** Widespread excitement and anticipation for the new All Wheel Park. Recognition of skateparks as essential community hubs for youth engagement and social interaction.
- **Design & Feature Preferences:** Strong preference for a more significant focus on the skatepark, potentially reducing the pump track size. Advanced BMX riders providing specific design input on features like rail heights and quarter pipe sizes.
- **Operational & Planning Insights:** Recommendations for careful selection of contractors and importance of budget contingency planning. Emphasis on adequate lighting for safety and extended park use.
- **Community & User Involvement:** Community gratitude and support for the project. Desire for a unique and distinctive design to set the park apart.
- **Budget & Resource Allocation Concerns:** Concerns about the distribution of funds between skatepark and pump track. Discussions on skateboarding’s cultural significance and potential for tourism and community development.
- **Accessibility & Inclusivity:** The park is seen as a potential focal point for residents and tourists, enhancing the waterfront area. Suggestions for an inclusive design catering to a wide range of users, from beginners to advanced riders.

Question 16: Beyond the Active Park terrain, are there any other amenities you’d like to see included?

80%	Lighting	60%	Washrooms	60%	Water Fountain
40%	Shade	40%	Landscaping	40%	Seating Areas

The feedback summarized here (in addition to a detailed analysis of the Project Scope/Budget & Existing Site Opportunities/Constraints) will be considered in the next phase of Concept Design Development. Please let us know if you have any questions or comments regarding this Survey Summary Report.

Sincerely,

Bill Gurney, OALA, CSLA
Landscape Architect, Senior Project Manager
New Line Skateparks Inc.

APPENDIX (A)

SCANNED FEEDBACK FORMS

KIWANIS ALL WHEEL PARK

WORKSHOP FEEDBACK FORM

Name: [REDACTED]

Age: 9

Email: [REDACTED]

1. What is your primary interest in this project?

- I'm a skateboarder I'm a BMX rider I'm a mountain biker I'm a roller skater / blader
 I'm a scooter rider I'm a parent / guardian or spectator
 Other (please specify) _____

2. How would you describe your skateboarding / riding ability?

- Beginner Intermediate Advanced I don't skate or ride

3. How often do you skate / ride?

- 3+ days a week 1-2 times a week 1-2 times a month I don't skate or ride

4. What part of the All Wheel Park interests you the most?

- Pump Track Skatepark

5. What's your favourite PUMP TRACK option, and why? Option #1 Option #2 Option #3

6. What's your favourite SKATEPARK option, and why? Option #1 Option #2 Option #3

7. Beyond the Pump Track and Skatepark facilities themselves, is there anything else you would like to see in the park? (i.e. seating / viewing spaces, landscaping, shade, washrooms, etc.)

NO LIGHTS ALL

8. General Comments. (use the adjacent box or back of this sheet if you need more space)

JUMP LINE

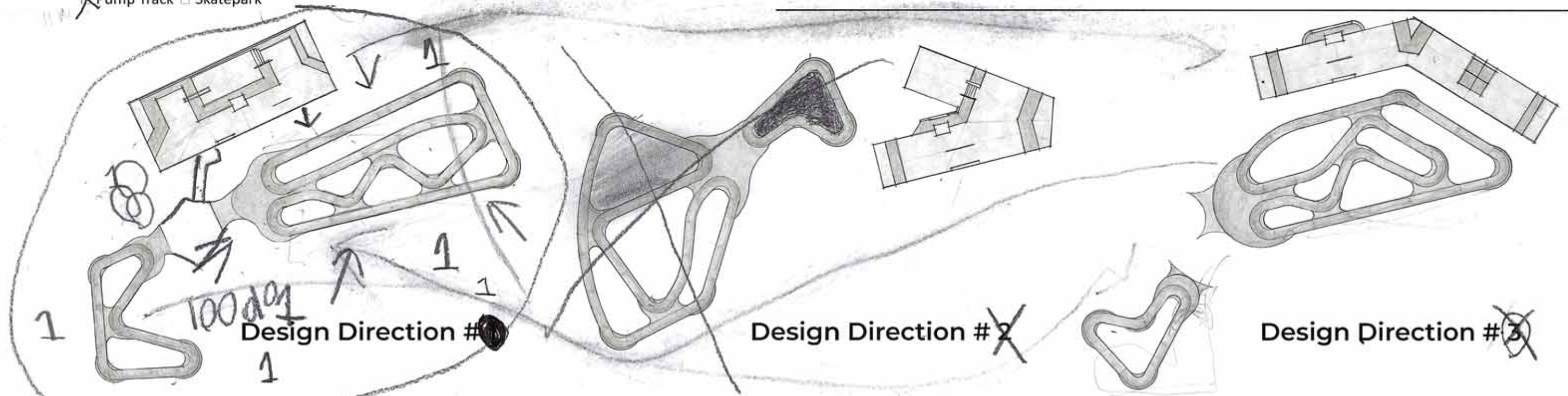

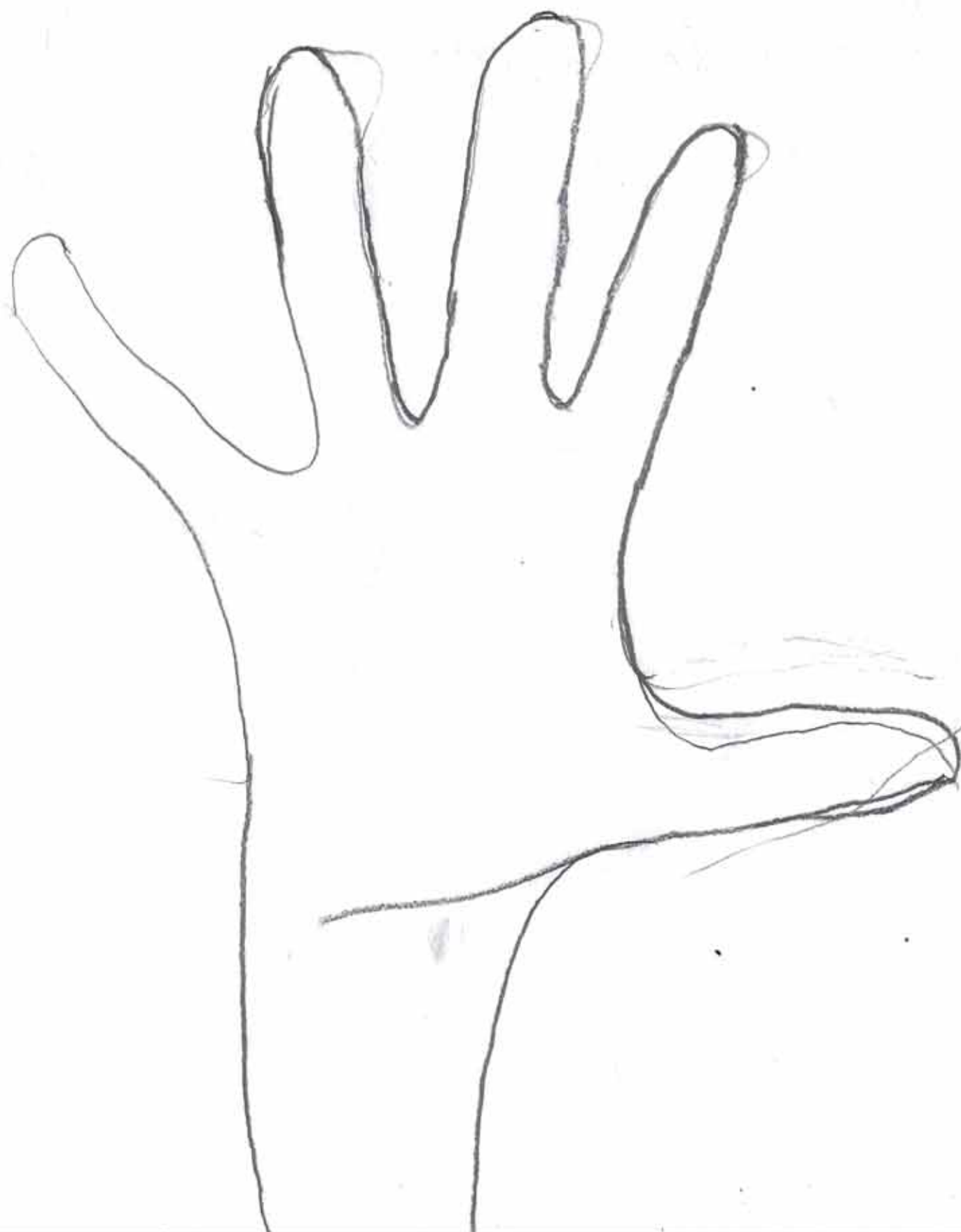

KIWANIS ALL WHEEL PARK

WORKSHOP FEEDBACK FORM

Name: [Redacted]
Email: [Redacted]

Age: 40

1. What is your primary interest in this project?
 I'm a skateboarder I'm a BMX rider I'm a mountain biker I'm a roller skater / blader
 I'm a scooter rider I'm a parent / guardian or spectator
 Other (please specify) _____

2. How would you describe your skateboarding / riding ability?
 Beginner Intermediate Advanced I don't skate or ride

3. How often do you skate / ride?
 3+ days a week 1-2 times a week 1-2 times a month I don't skate or ride

4. What part of the All Wheel Park interests you the most?
 Pump Track Skatepark

5. What's your favourite PUMP TRACK option, and why? Option #1 Option #2 Option #3

6. What's your favourite SKATEPARK option, and why? Option #1 Option #2 Option #3

7. Beyond the Pump Track and Skatepark facilities themselves, is there anything else you would like to see in the park?
(i.e. seating / viewing spaces, landscaping, shade, washrooms, etc.)
Nights for the all wheel park

8. General Comments. (use the adjacent box or back of this sheet if you need more space)
Need jump line
2 lip.

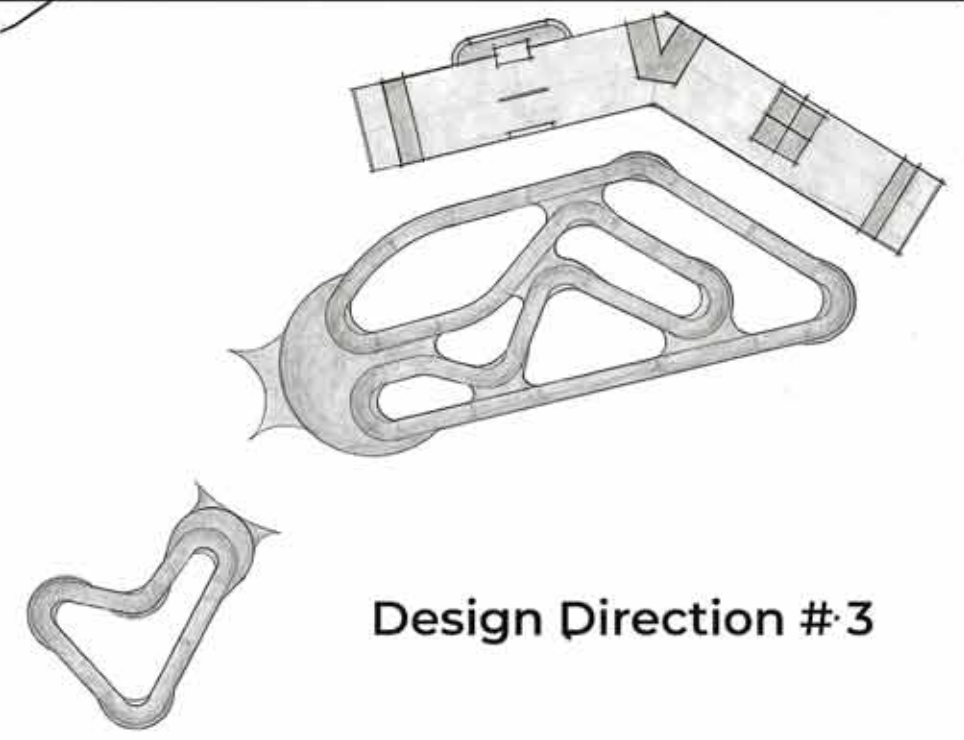
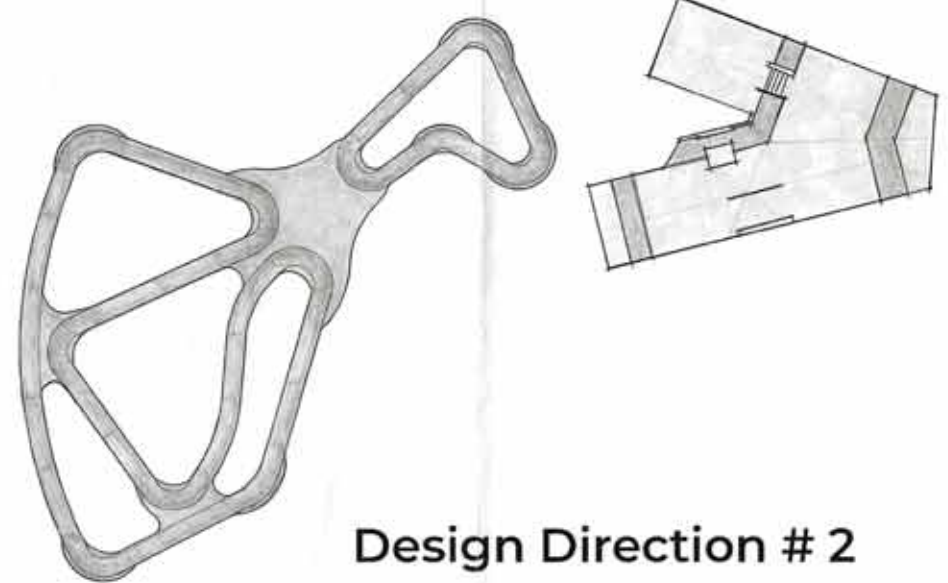
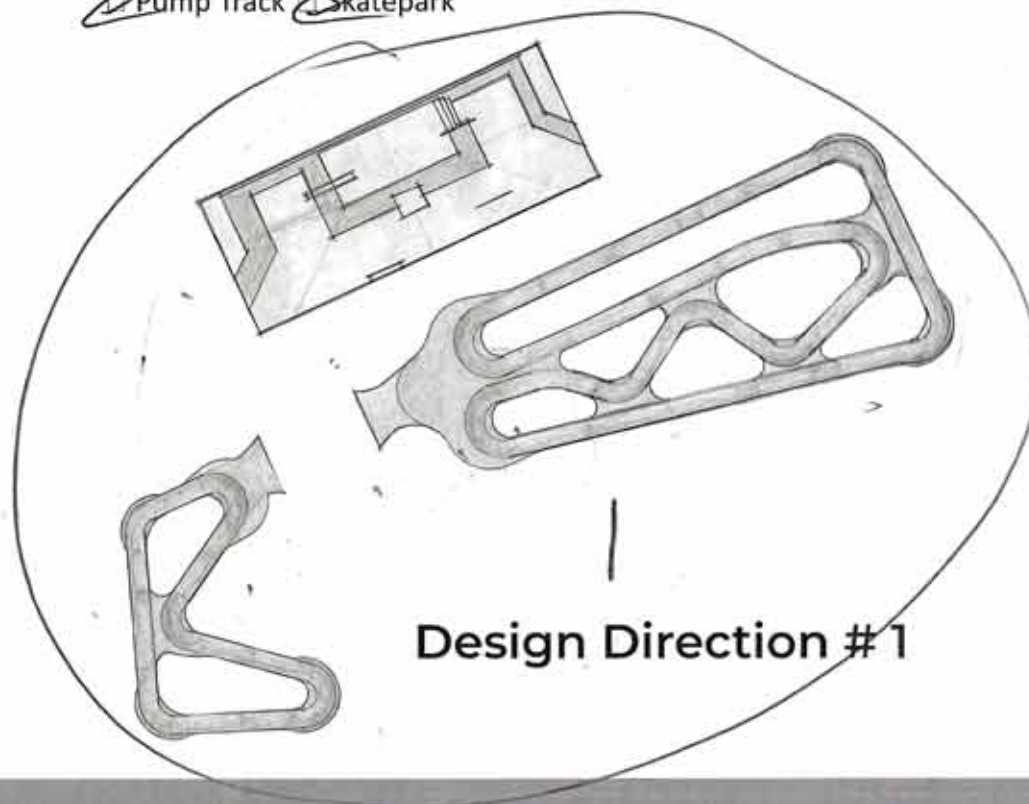

2

KIWANIS ALL WHEEL PARK

WORKSHOP FEEDBACK FORM

Name: [REDACTED] Age: 32

Email: [REDACTED]

1. What is your primary interest in this project?

- I'm a skateboarder I'm a BMX rider I'm a mountain biker I'm a roller skater / blader
 I'm a scooter rider I'm a parent / guardian or spectator
 Other (please specify) _____

2. How would you describe your skateboarding / riding ability?

- Beginner Intermediate Advanced I don't skate or ride

3. How often do you skate / ride?

- 3+ days a week 1-2 times a week 1-2 times a month I don't skate or ride

4. What part of the All Wheel Park interests you the most?

- Pump Track Skatepark

5. What's your favourite PUMP TRACK option, and why? Option #1 Option #2 Option #3

6. What's your favourite SKATEPARK option, and why? Option #1 Option #2 Option #3

NO LESS THAN FOUR STAZES

7. Beyond the Pump Track and Skatepark facilities themselves, is there anything else you would like to see in the park?
(i.e. seating / viewing spaces, landscaping, shade, washrooms, etc.)

LIGHTING

8. General Comments. (use the adjacent box or back of this sheet if you need more space)

NO SLAPPY BANK W/ INSET MANUAL PAD

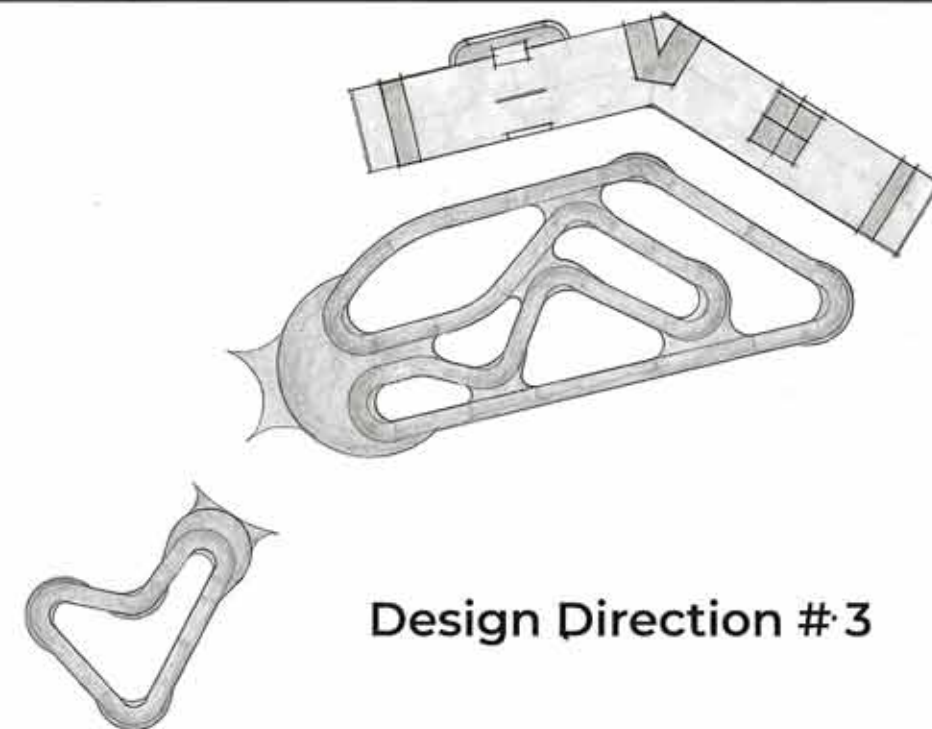
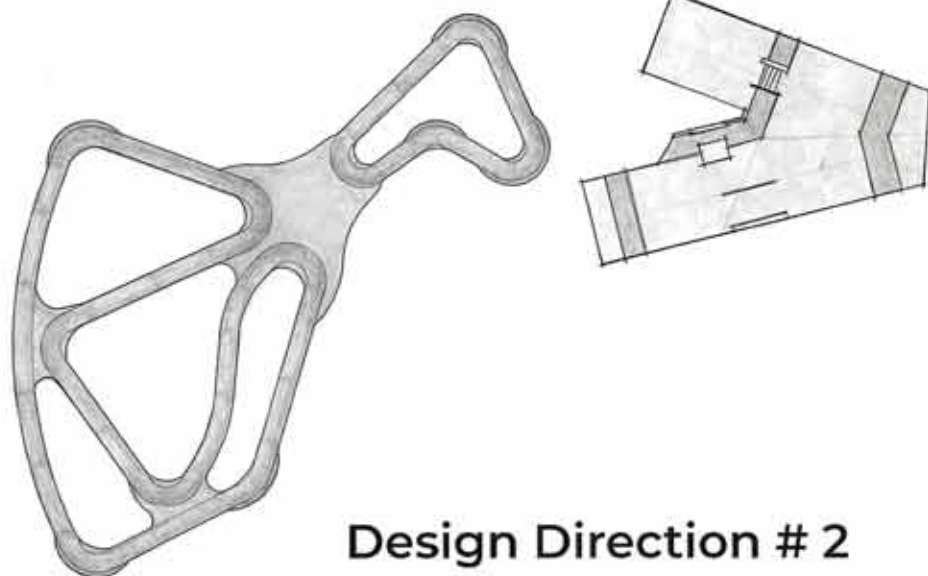
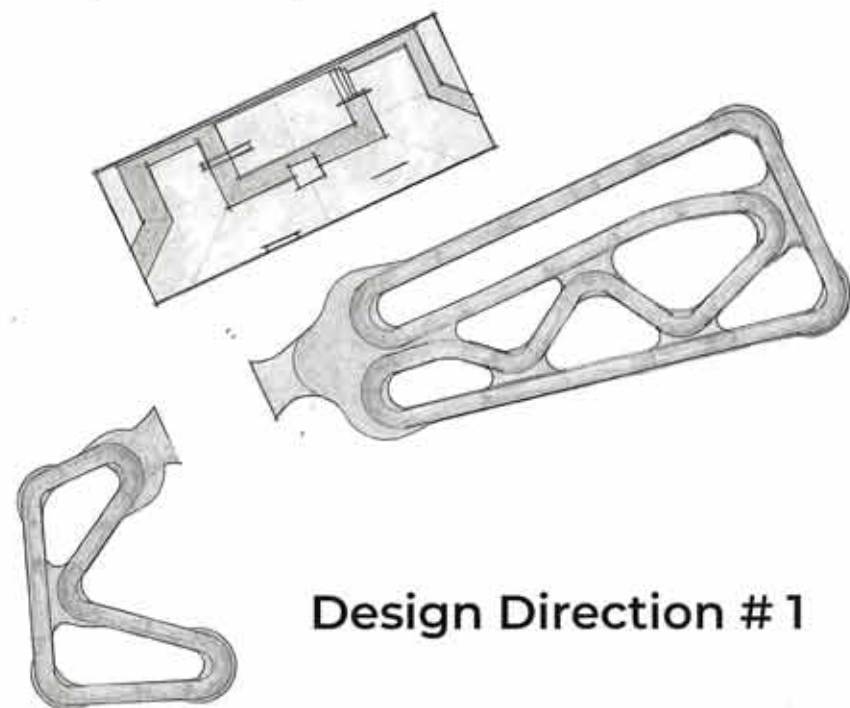

3

KIWANIS ALL WHEEL PARK

WORKSHOP FEEDBACK FORM

Name: [Redacted]
Email: [Redacted]

Age: 49

1. What is your primary interest in this project?

- I'm a skateboarder I'm a BMX rider I'm a mountain biker I'm a roller skater / blader
 I'm a scooter rider I'm a parent / guardian or spectator
 Other (please specify) _____

2. How would you describe your skateboarding / riding ability?

- Beginner Intermediate Advanced I don't skate or ride

3. How often do you skate / ride?

- 3+ days a week 1-2 times a week 1-2 times a month I don't skate or ride

4. What part of the All Wheel Park interests you the most?

- Pump Track Skatepark

5. What's your favourite PUMP TRACK option, and why? Option #1 Option #2 Option #3

ATTRACTIVE OVERALL DESIGN.

6. What's your favourite SKATEPARK option, and why? Option #1 Option #2 Option #3

I LIKE THE WIDTH COMPARED TO #2 & #3
SKATES WELL BOTH WAYS (REGGIE VS GOODBALL)

7. Beyond the Pump Track and Skatepark facilities themselves, is there anything else you would like to see in the park?
(i.e. seating / viewing spaces, landscaping, shade, washrooms, etc.)

EXTRA LIGHTING - ALL NIGHT LIGHTING,

8. General Comments. (use the adjacent box or back of this sheet if you need more space)

LOTS OF LIGHTS - ALL NIGHT LIGHTING PLS.

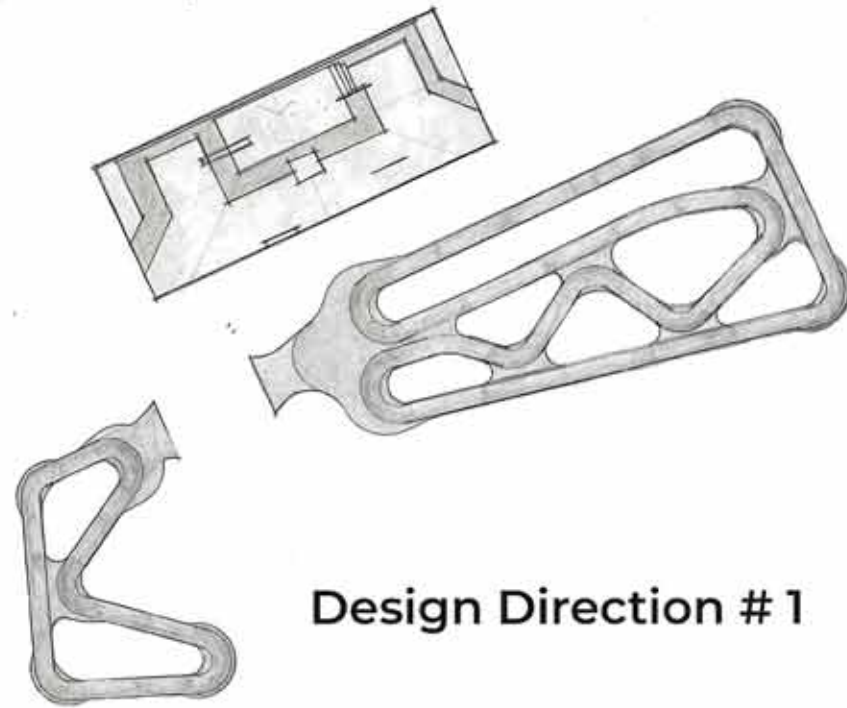

Design Direction #1

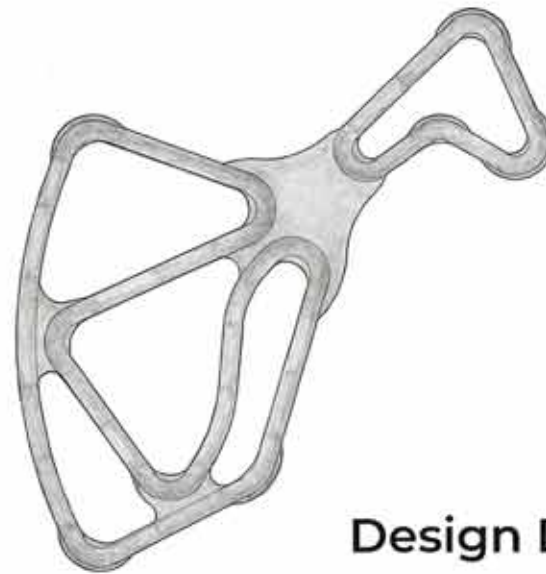

Design Direction #2

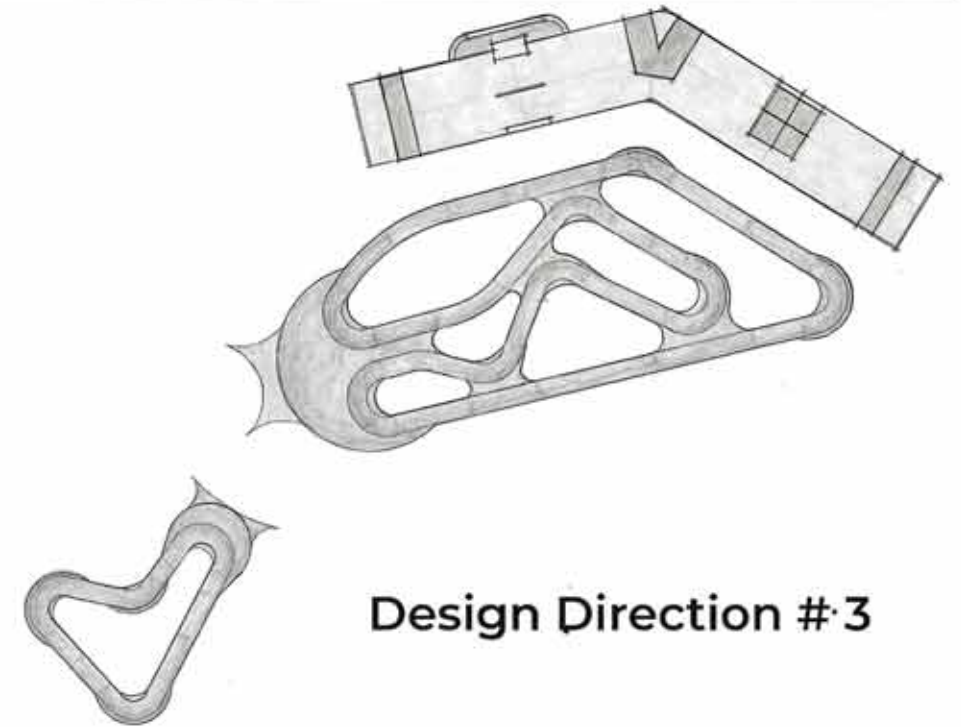

Design Direction #3

4

KIWANIS ALL WHEEL PARK

WORKSHOP FEEDBACK FORM

Name: [Redacted] Age: 38

Email: [Redacted]

1. What is your primary interest in this project?

- I'm a skateboarder I'm a BMX rider I'm a mountain biker I'm a roller skater / blader
 I'm a scooter rider I'm a parent / guardian or spectator
 Other (please specify) rollerblader/ICE CROSS

2. How would you describe your skateboarding / riding ability?

- Beginner Intermediate Advanced I don't skate or ride

3. How often do you skate / ride?

- 3+ days a week 1-2 times a week 1-2 times a month I don't skate or ride

4. What part of the All Wheel Park interests you the most?

- Pump Track Skatepark

5. What's your favourite PUMP TRACK option, and why? Option #1 Option #2 Option #3

Love both beginner and intermediate skill levels are included in design and all meet at one ~~beginning~~ viewing area

6. What's your favourite SKATEPARK option, and why? Option #1 Option #2 Option #3

I like the multi level view this park will have

7. Beyond the Pump Track and Skatepark facilities themselves, is there anything else you would like to see in the park? (i.e. seating / viewing spaces, landscaping, shade, washrooms, etc.)

Shade in rest / communal area
Have seating available for parents.

8. General Comments. (use the adjacent box or back of this sheet if you need more space)

Awesome that Velsolutions is building pump track!
Very happy with this selection

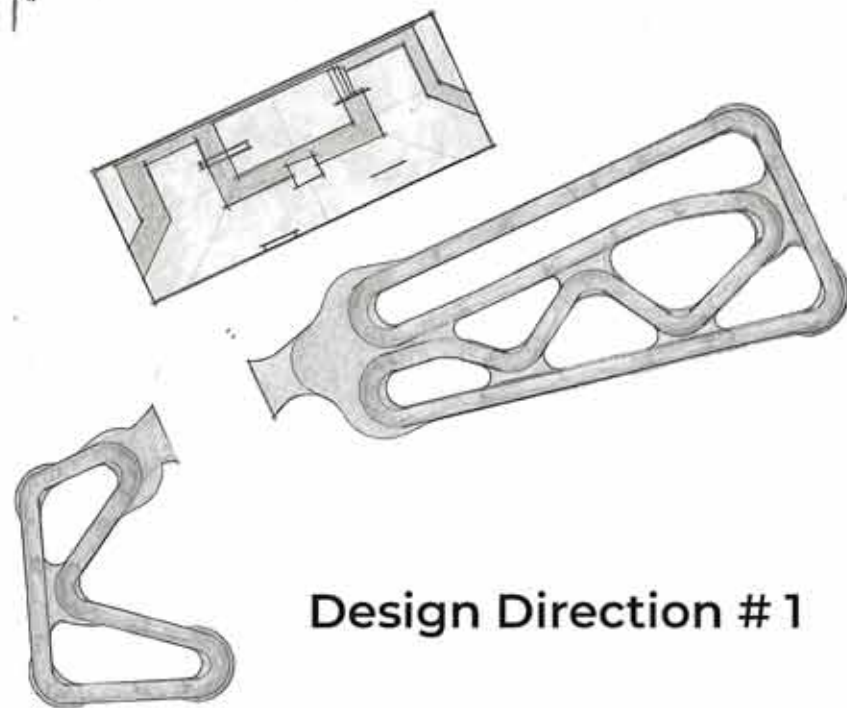

Design Direction #1

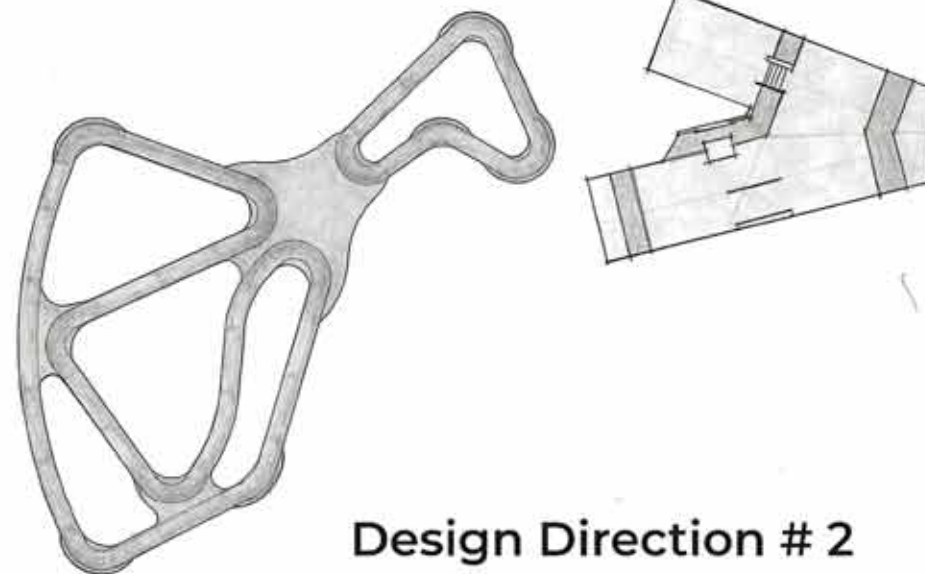

Design Direction #2

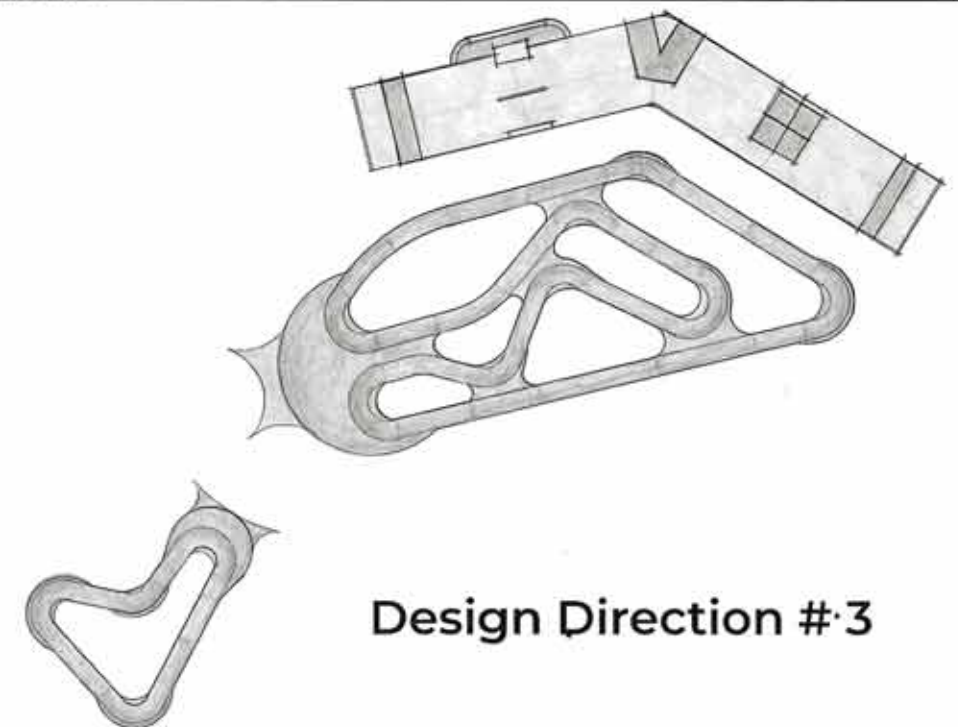

Design Direction #3

5

KIWANIS ALL WHEEL PARK

WORKSHOP FEEDBACK FORM

Name: [REDACTED]
 Email: [REDACTED]

Age: 30

1. What is your primary interest in this project?

- I'm a skateboarder
- I'm a BMX rider
- I'm a mountain biker
- I'm a roller skater / blader
- I'm a scooter rider
- I'm a parent / guardian or spectator
- Other (please specify) Ramp Builder + Community Organiser

2. How would you describe your skateboarding / riding ability?

- Beginner
- Intermediate
- Advanced
- I don't skate or ride

3. How often do you skate / ride?

- 3+ days a week
- 1-2 times a week
- 1-2 times a month
- I don't skate or ride

4. What part of the All Wheel Park interests you the most?

- Pump Track
- Skatepark

5. What's your favourite PUMP TRACK option, and why? Option #1 Option #2 Option #3

It looks very spacious + conducive to lots of open pumping, shredding. It seems to take up the best amount of the free space.

6. What's your favourite SKATEPARK option, and why? Option #1 Option #2 Option #3

LINES, Flow. there will be alot of mixed medium (BMX/scoot/board) so openness is key. Flow.

7. Beyond the Pump Track and Skatepark facilities themselves, is there anything else you would like to see in the park? (i.e. seating / viewing spaces, landscaping, shade, washrooms, etc.)

lighting, shaded area, concessions (food truck) parking.

8. General Comments. (use the adjacent box or back of this sheet if you need more space)

Stoked !!!

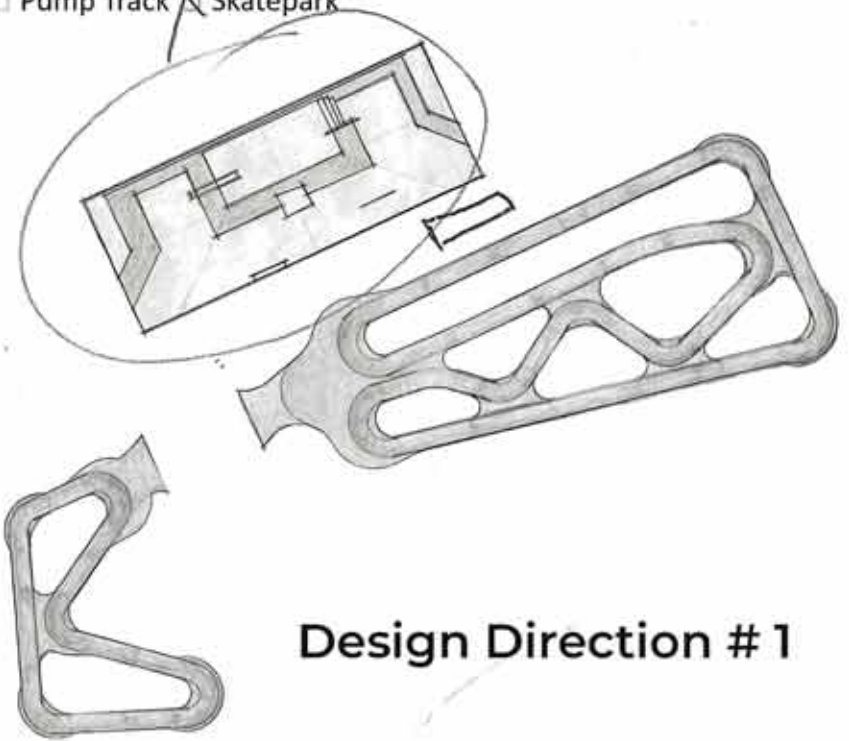

Design Direction #1

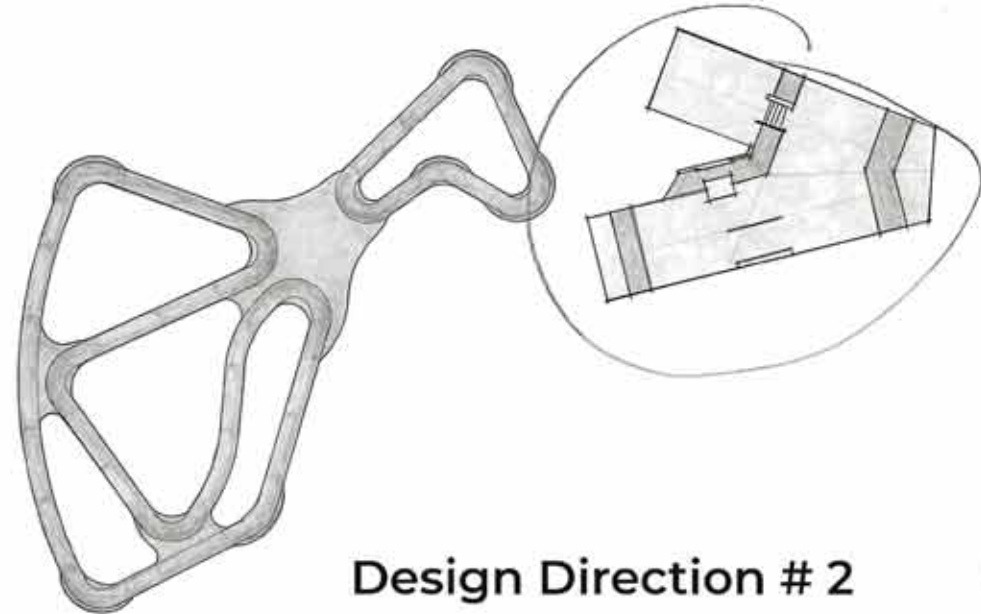

Design Direction #2

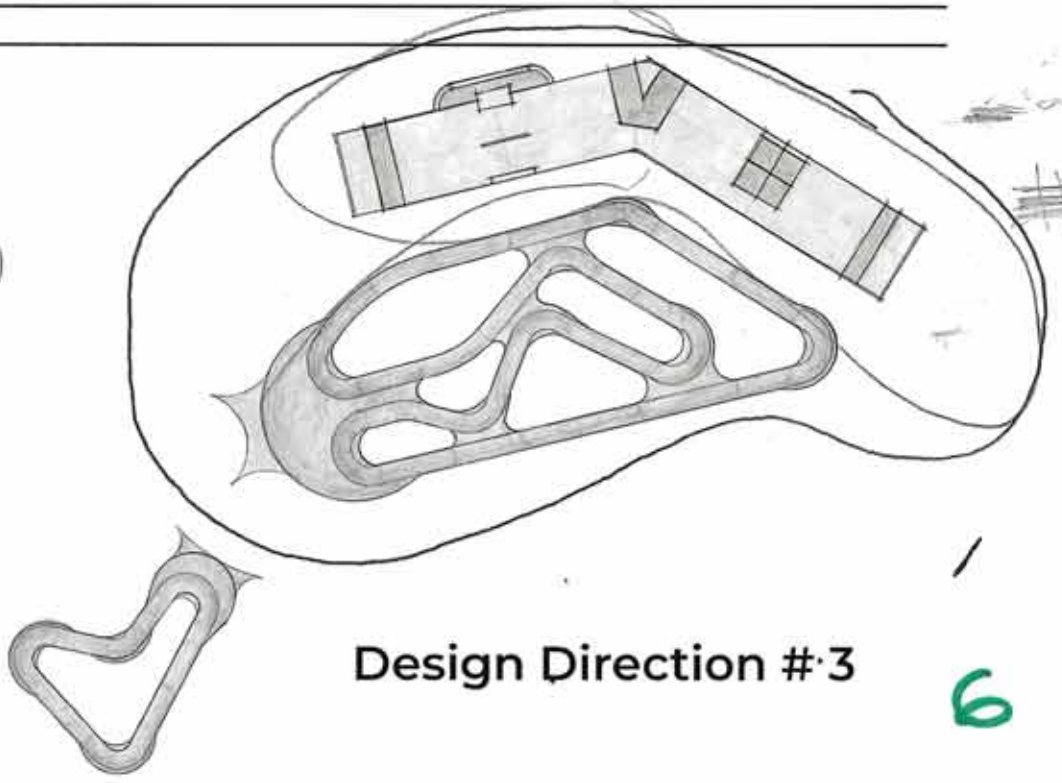

Design Direction #3

6

KIWANIS ALL WHEEL PARK

WORKSHOP FEEDBACK FORM

Name: [REDACTED] Age: 41

Email: [REDACTED]

1. What is your primary interest in this project?

- I'm a skateboarder
 I'm a BMX rider
 I'm a mountain biker
 I'm a roller skater / blader
 I'm a scooter rider
 I'm a parent / guardian or spectator
 Other (please specify) _____

2. How would you describe your skateboarding / riding ability?

- Beginner
 Intermediate
 Advanced
 I don't skate or ride

3. How often do you skate / ride?

- 3+ days a week
 1-2 times a week
 1-2 times a month
 I don't skate or ride

4. What part of the All Wheel Park interests you the most?

- Pump Track
 Skatepark

5. What's your favourite PUMP TRACK option, and why?
 Option #1
 Option #2
 Option #3

Shape, lots of turn, tight course

6. What's your favourite SKATEPARK option, and why?
 Option #1
 Option #2
 Option #3

Size
that may possibly include a street section

7. Beyond the Pump Track and Skatepark facilities themselves, is there anything else you would like to see in the park? (i.e. seating / viewing spaces, landscaping, shade, washrooms, etc.)

8. General Comments. (use the adjacent box or back of this sheet if you need more space)

Great work !! lights on pump track

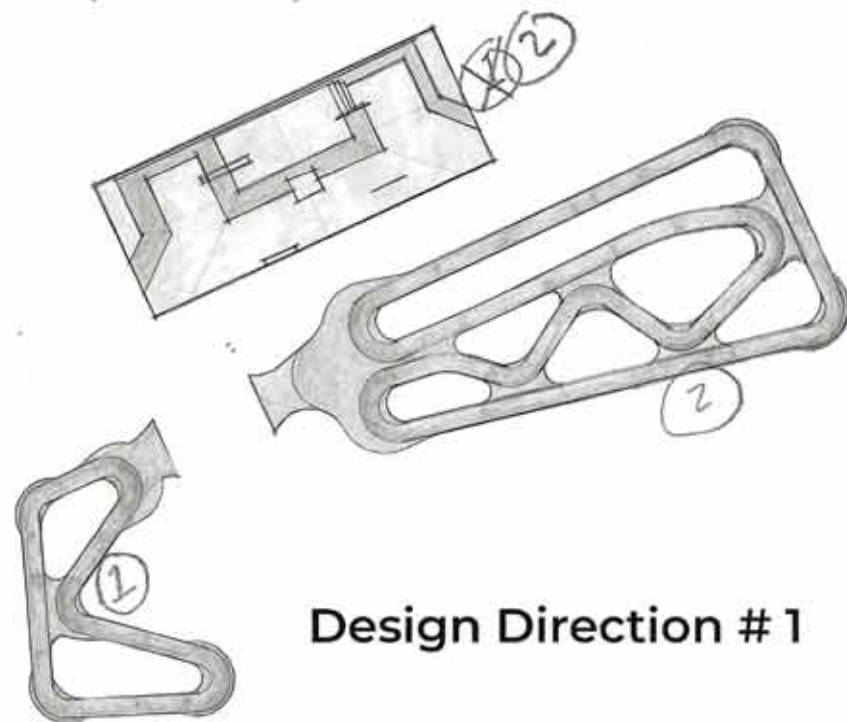

Design Direction #1

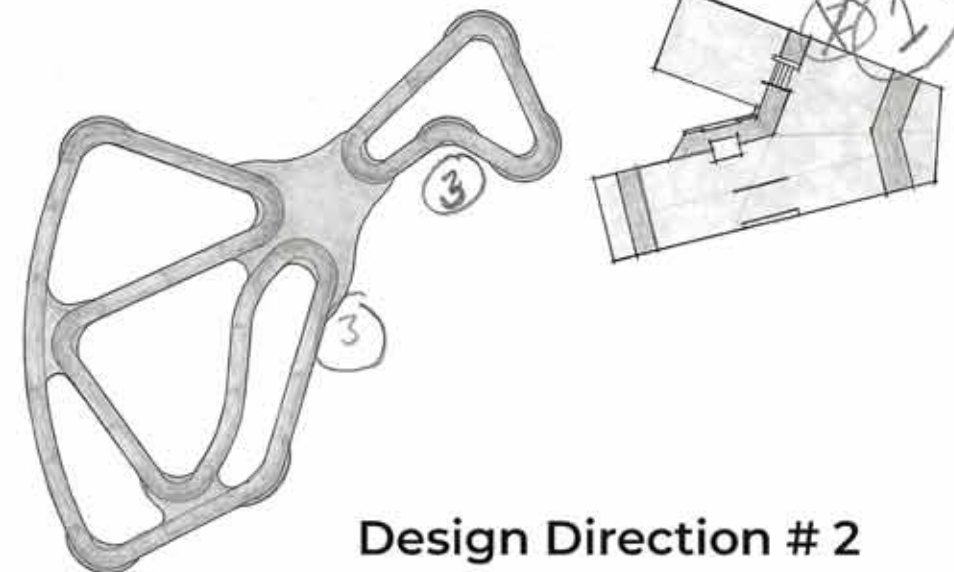

Design Direction #2

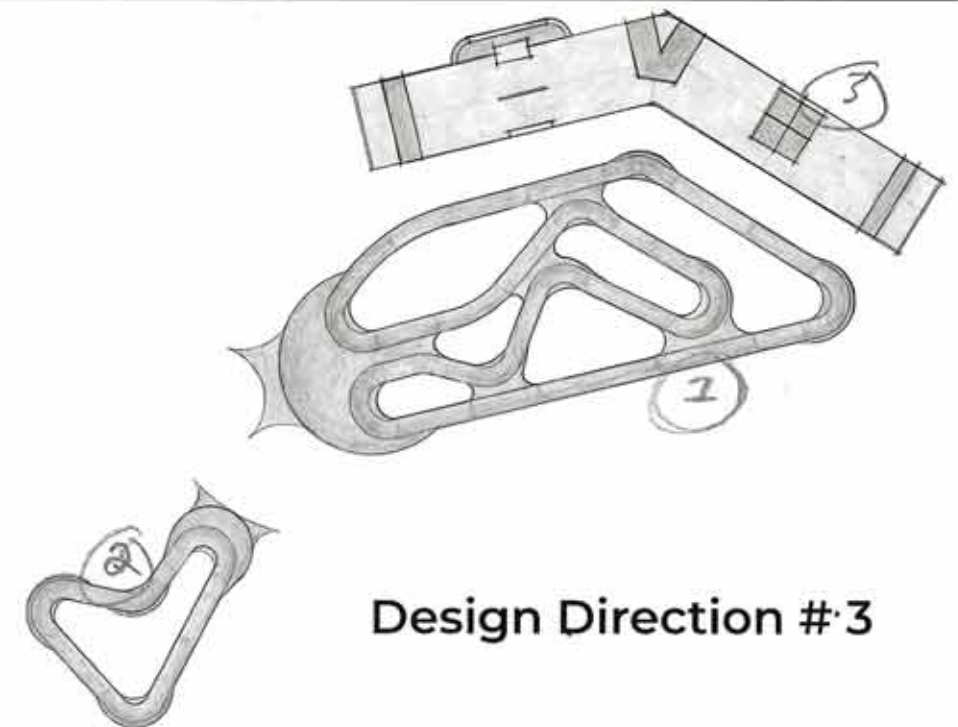

Design Direction #3

7

KIWANIS ALL WHEEL PARK

WORKSHOP FEEDBACK FORM

Name: [REDACTED]

Age: 40

Email: [REDACTED]

1. What is your primary interest in this project?

- I'm a skateboarder I'm a BMX rider I'm a mountain biker I'm a roller skater / blader
 I'm a scooter rider I'm a parent / guardian or spectator
 Other (please specify) _____

2. How would you describe your skateboarding / riding ability?

- Beginner Intermediate Advanced I don't skate or ride

3. How often do you skate / ride?

- 3+ days a week 1-2 times a week 1-2 times a month I don't skate or ride

4. What part of the All Wheel Park interests you the most?

- Pump Track Skatepark

5. What's your favourite PUMP TRACK option, and why? Option #1 Option #2 Option #3

6. What's your favourite SKATEPARK option, and why? Option #1 Option #2 Option #3

BEST FLOW

7. Beyond the Pump Track and Skatepark facilities themselves, is there anything else you would like to see in the park?
(i.e. seating / viewing spaces, landscaping, shade, washrooms, etc.)

MORE SKATEPARK

8. General Comments. (use the adjacent box or back of this sheet if you need more space)

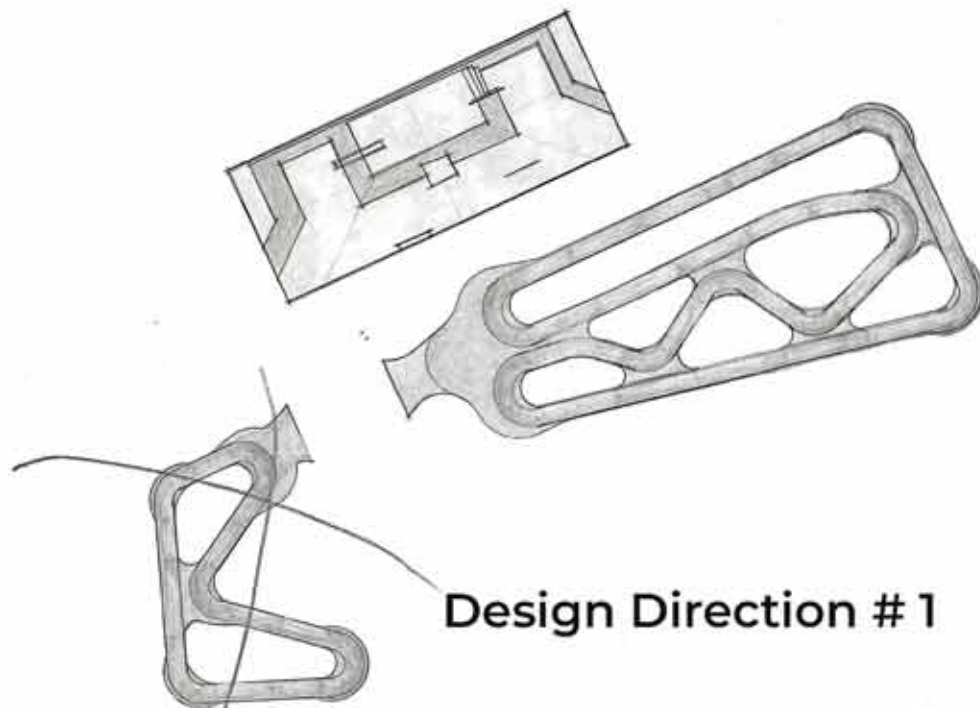

Design Direction #1

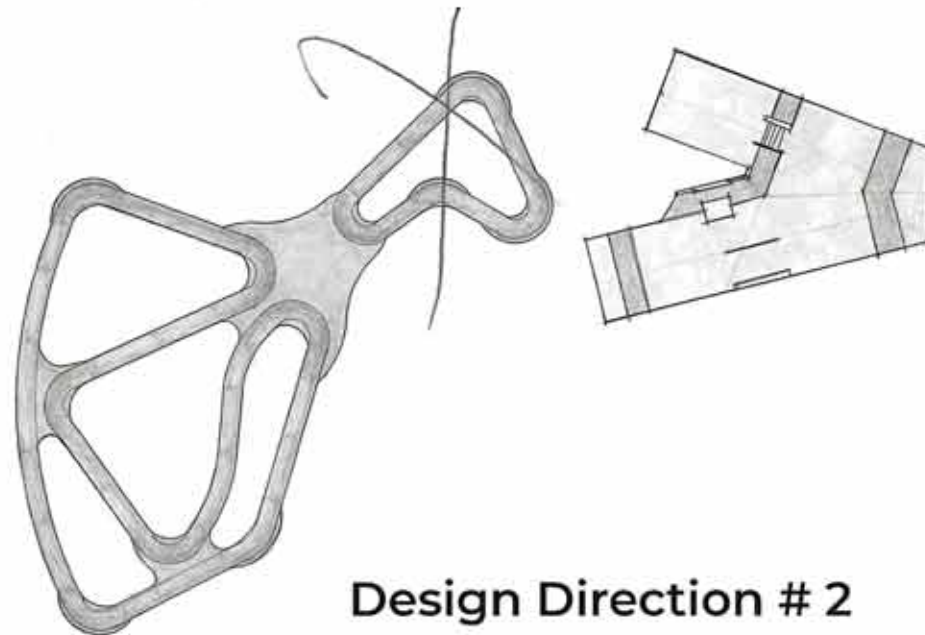

Design Direction #2

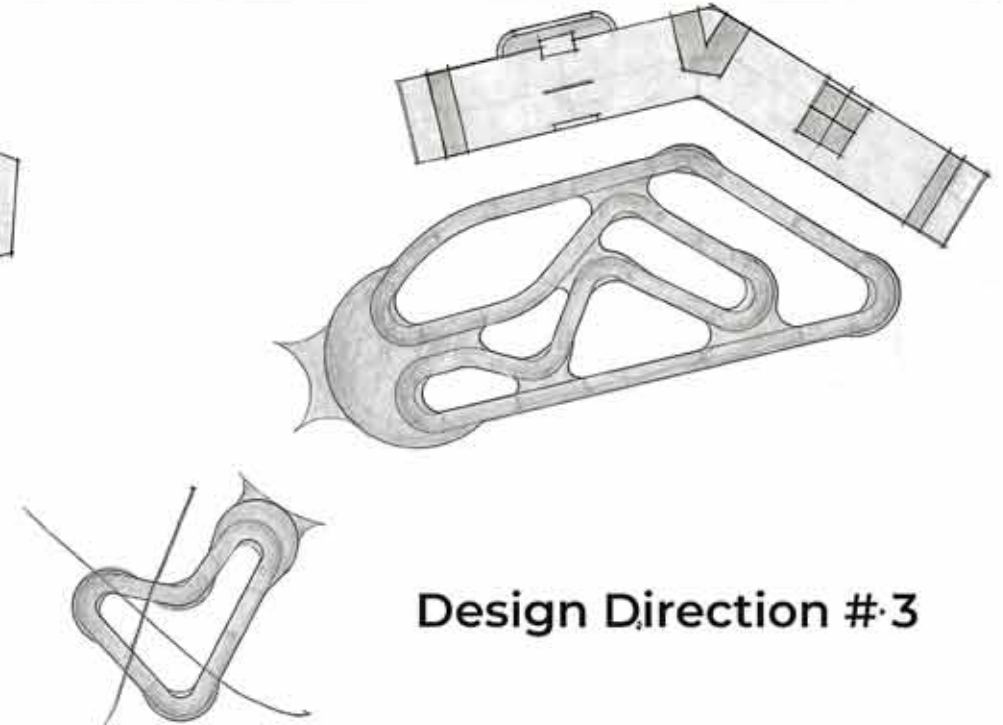

Design Direction #3

KIWANIS ALL WHEEL PARK

WORKSHOP FEEDBACK FORM

Name: [Redacted]
Email: [Redacted]

Age: 26

1. What is your primary interest in this project?
 I'm a skateboarder I'm a BMX rider I'm a mountain biker I'm a roller skater / blader
 I'm a scooter rider I'm a parent / guardian or spectator
 Other (please specify) _____
2. How would you describe your skateboarding / riding ability?
 Beginner Intermediate Advanced I don't skate or ride
3. How often do you skate / ride?
 3+ days a week 1-2 times a week 1-2 times a month I don't skate or ride
4. What part of the All Wheel Park interests you the most?
 Pump Track Skatepark

5. What's your favourite PUMP TRACK option, and why? Option #1 Option #2 Option #3
This one would be the most playful and enjoyable
has the most Dextrous Features
6. What's your favourite SKATEPARK option, and why? Option #1 Option #2 Option #3

7. Beyond the Pump Track and Skatepark facilities themselves, is there anything else you would like to see in the park?
(i.e. seating / viewing spaces, landscaping, shade, washrooms, etc.)

8. General Comments. (use the adjacent box or back of this sheet if you need more space)

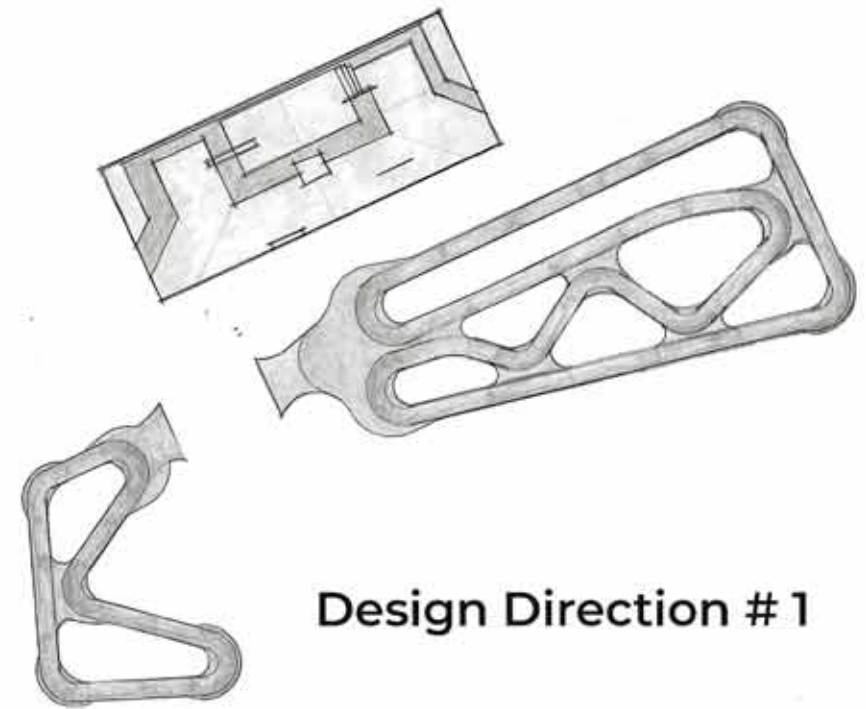

Design Direction #1

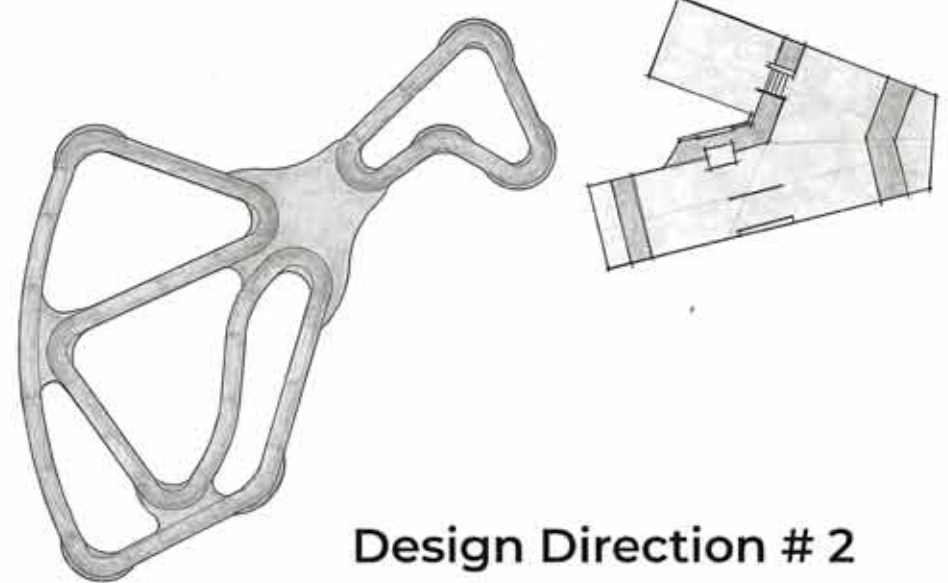

Design Direction #2

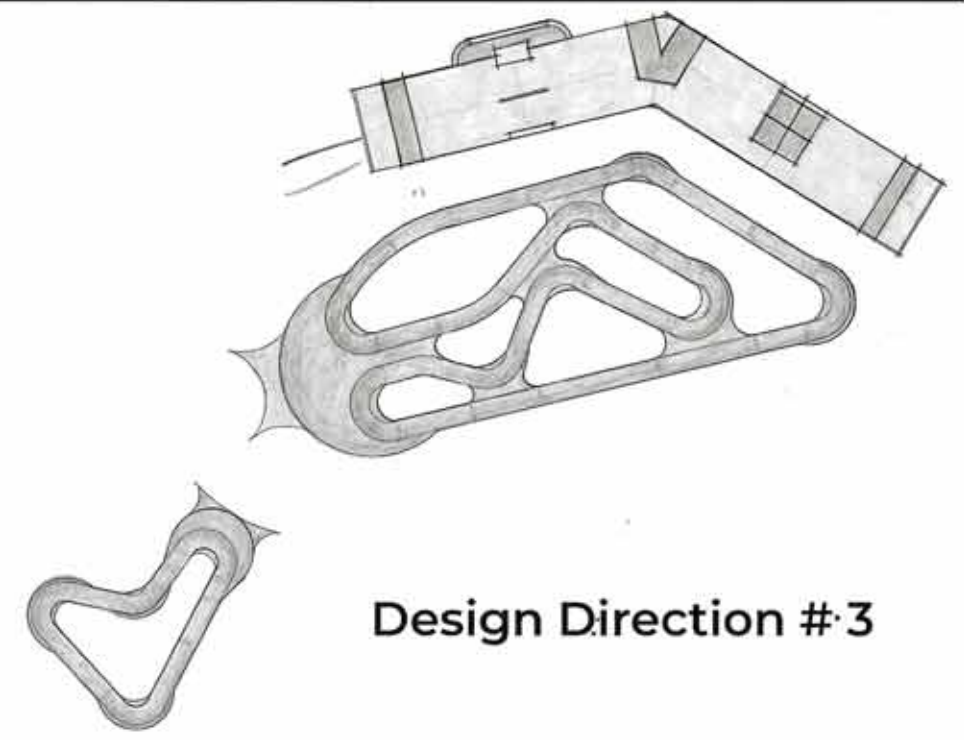

Design Direction #3

9

KIWANIS ALL WHEEL PARK

WORKSHOP FEEDBACK FORM

Name: [Redacted]

Age: 48

Email: [Redacted]

1. What is your primary interest in this project?

- I'm a skateboarder I'm a BMX rider I'm a mountain biker I'm a roller skater / blader
 I'm a scooter rider I'm a parent / guardian or spectator
 Other (please specify) _____

2. How would you describe your skateboarding / riding ability?

- Beginner Intermediate Advanced I don't skate or ride

3. How often do you skate / ride?

- 3+ days a week 1-2 times a week 1-2 times a month I don't skate or ride

4. What part of the All Wheel Park interests you the most?

- Pump Track Skatepark

5. What's your favourite PUMP TRACK option, and why? Option #1 Option #2 Option #3

The rhythm section sounds fun.

6. What's your favourite SKATEPARK option, and why? Option #1 Option #2 Option #3

It has the best flow.

7. Beyond the Pump Track and Skatepark facilities themselves, is there anything else you would like to see in the park?
(i.e. seating / viewing spaces, landscaping, shade, washrooms, etc.)

8. General Comments. (use the adjacent box or back of this sheet if you need more space)

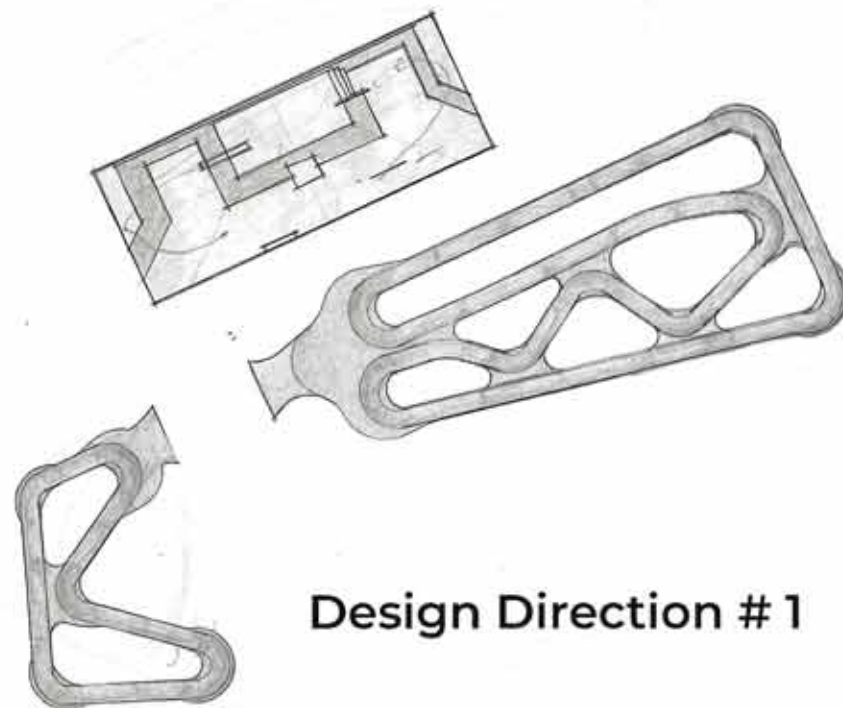

Design Direction #1

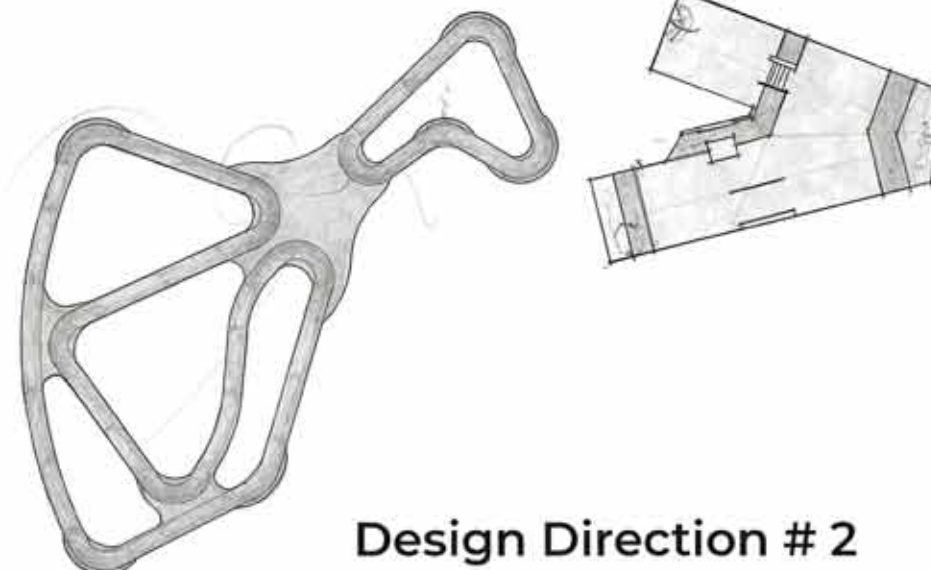

Design Direction #2

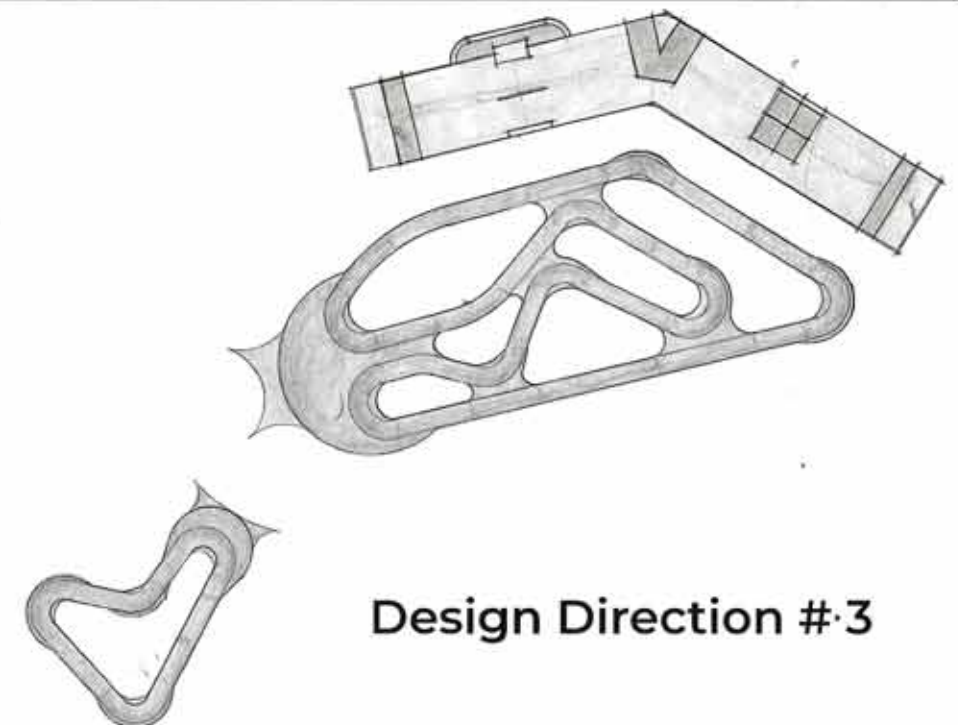

Design Direction #3

10

KIWANIS ALL WHEEL PARK

WORKSHOP FEEDBACK FORM

Name: [REDACTED] Age: 56

Email: [REDACTED]

1. What is your primary interest in this project?

- I'm a skateboarder I'm a BMX rider I'm a mountain biker I'm a roller skater / blader
 I'm a scooter rider I'm a parent / guardian or spectator
 Other (please specify) _____

2. How would you describe your skateboarding / riding ability?

- Beginner Intermediate Advanced I don't skate or ride

3. How often do you skate / ride?

- 3+ days a week 1-2 times a week 1-2 times a month I don't skate or ride

4. What part of the All Wheel Park interests you the most?

- Pump Track Skatepark

5. What's your favourite PUMP TRACK option, and why? Option #1 Option #2 Option #3

Not really a skater or BMX so n

6. What's your favourite SKATEPARK option, and why? Option #1 Option #2 Option #3

2 ~~seems~~ might have congestion
I like how / sites on slope

7. Beyond the Pump Track and Skatepark facilities themselves, is there anything else you would like to see in the park?
(i.e. seating / viewing spaces, landscaping, shade, washrooms, etc.)

shade, bike racks

8. General Comments. (use the adjacent box or back of this sheet if you need more space)

less pathway on option 1 is a plus

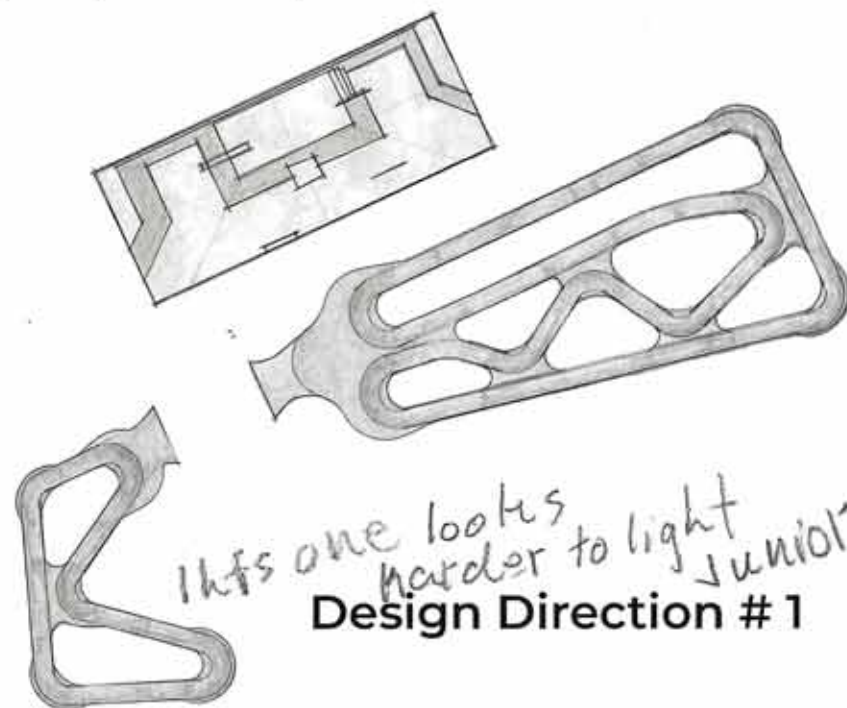

Design Direction #1

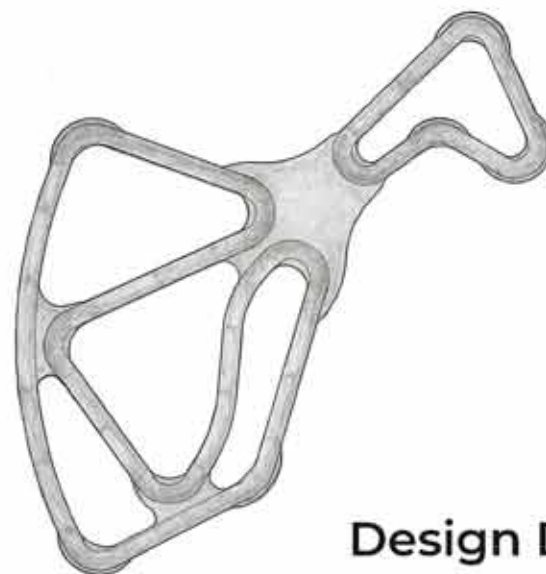

Design Direction #2

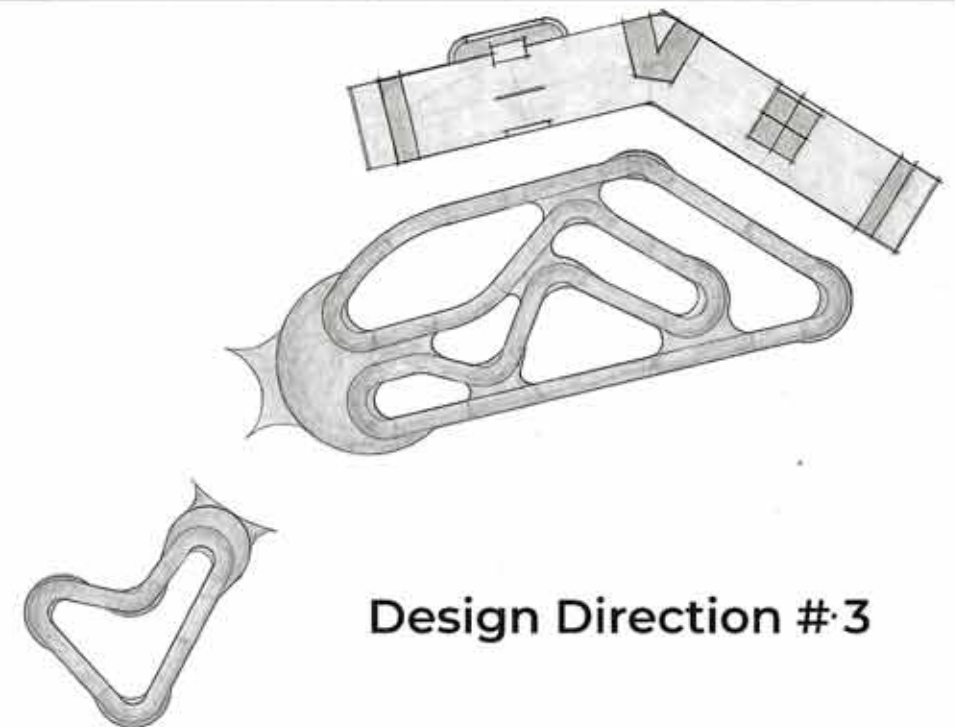

Design Direction #3

KIWANIS ALL WHEEL PARK

WORKSHOP FEEDBACK FORM

Name: [Redacted] Age: 19

Email: [Redacted]

1. What is your primary interest in this project?

- I'm a skateboarder I'm a BMX rider I'm a mountain biker I'm a roller skater / blader
 I'm a scooter rider I'm a parent / guardian or spectator
 Other (please specify) _____

2. How would you describe your skateboarding / riding ability?

- Beginner Intermediate Advanced I don't skate or ride

3. How often do you skate / ride?

- 3+ days a week 1-2 times a week 1-2 times a month I don't skate or ride

4. What part of the All Wheel Park interests you the most?

- Pump Track Skatepark

5. What's your favourite PUMP TRACK option, and why? Option #1 Option #2 Option #3

Good Design / No Beginner design Pump track, which seems useless.

6. What's your favourite SKATEPARK option, and why? Option #1 Option #2 Option #3

Good Flow, options to connect different obstacles in the same run.

7. Beyond the Pump Track and Skatepark facilities themselves, is there anything else you would like to see in the park?
(i.e. seating / viewing spaces, landscaping, shade, washrooms, etc.)

Shade, Water Fountain, Skatepark lighting

8. General Comments. (use the adjacent box or back of this sheet if you need more space)

The down rails would be nice if they were Flat to Down Rails
for example, they provide more use

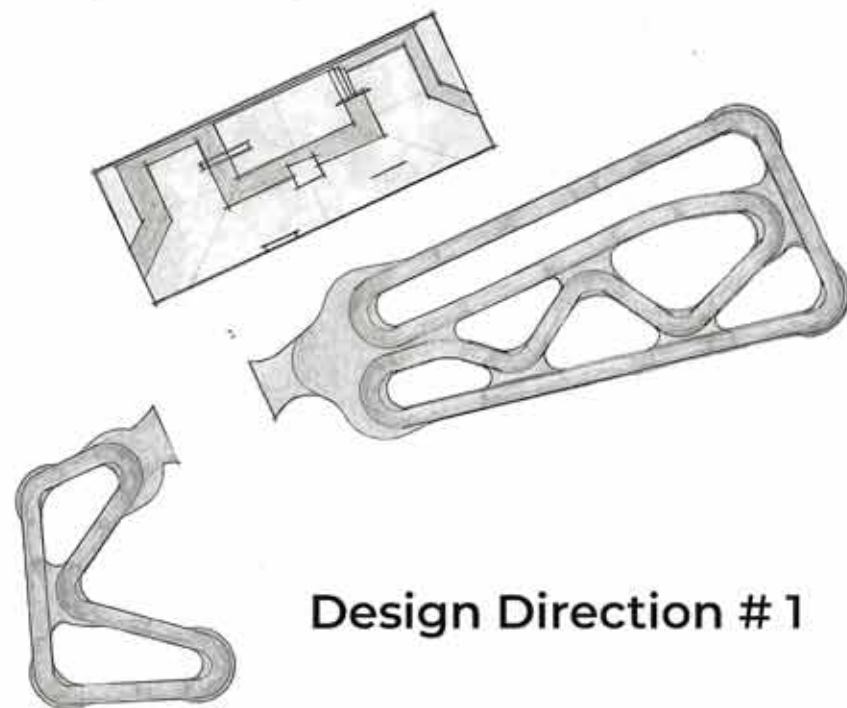
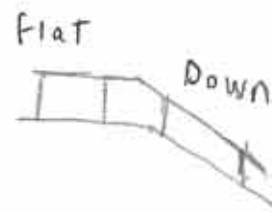

Design Direction #1

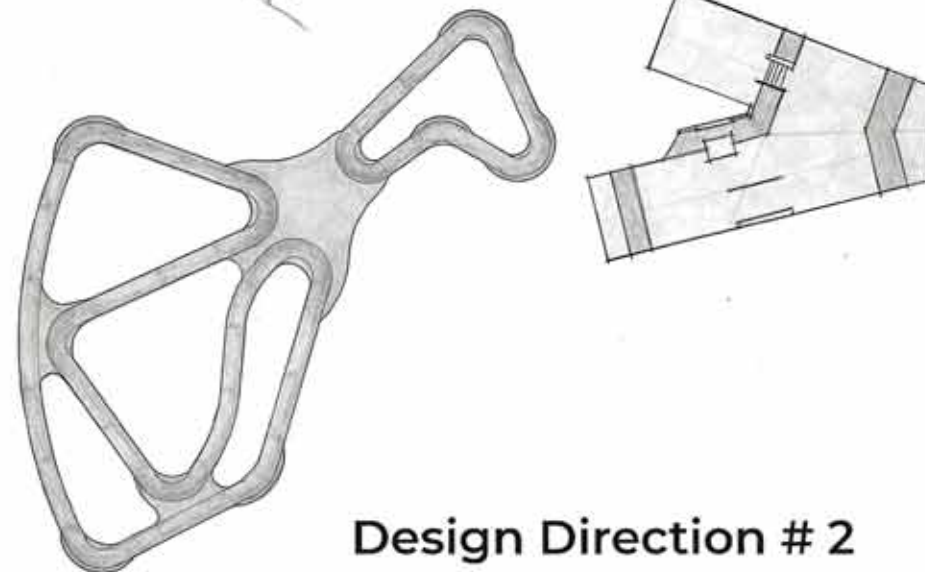

Design Direction #2

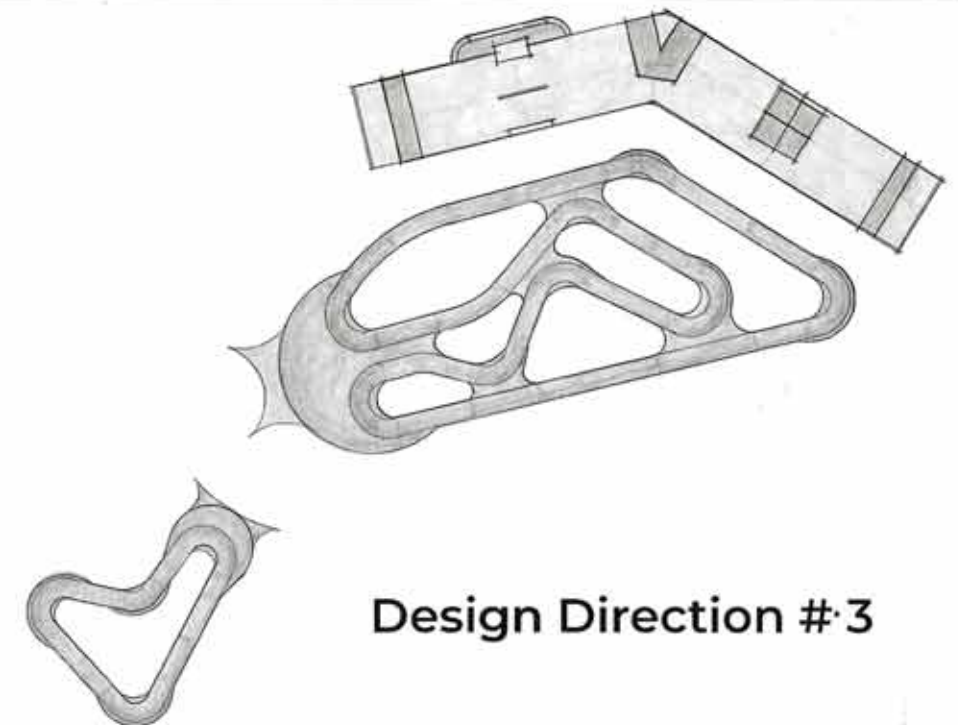

Design Direction #3

12

KIWANIS ALL WHEEL PARK

WORKSHOP FEEDBACK FORM

Name: [REDACTED] Age: 26

Email: [REDACTED]@il.com

1. What is your primary interest in this project?

- I'm a skateboarder I'm a BMX rider I'm a mountain biker I'm a roller skater / blader
 I'm a scooter rider I'm a parent / guardian or spectator
 Other (please specify) _____

2. How would you describe your skateboarding / riding ability?

- Beginner Intermediate Advanced I don't skate or ride

3. How often do you skate / ride?

- 3+ days a week 1-2 times a week 1-2 times a month I don't skate or ride

4. What part of the All Wheel Park interests you the most?

- Pump Track Skatepark

5. What's your favourite PUMP TRACK option, and why? Option #1 Option #2 Option #3

6. What's your favourite SKATEPARK option, and why? Option #1 Option #2 Option #3

7. Beyond the Pump Track and Skatepark facilities themselves, is there anything else you would like to see in the park?
(i.e. seating / viewing spaces, landscaping, shade, washrooms, etc.)

8. General Comments. (use the adjacent box or back of this sheet if you need more space)

MOST FLOW LESS CONGESTION AREA

WATER FOUNTAIN

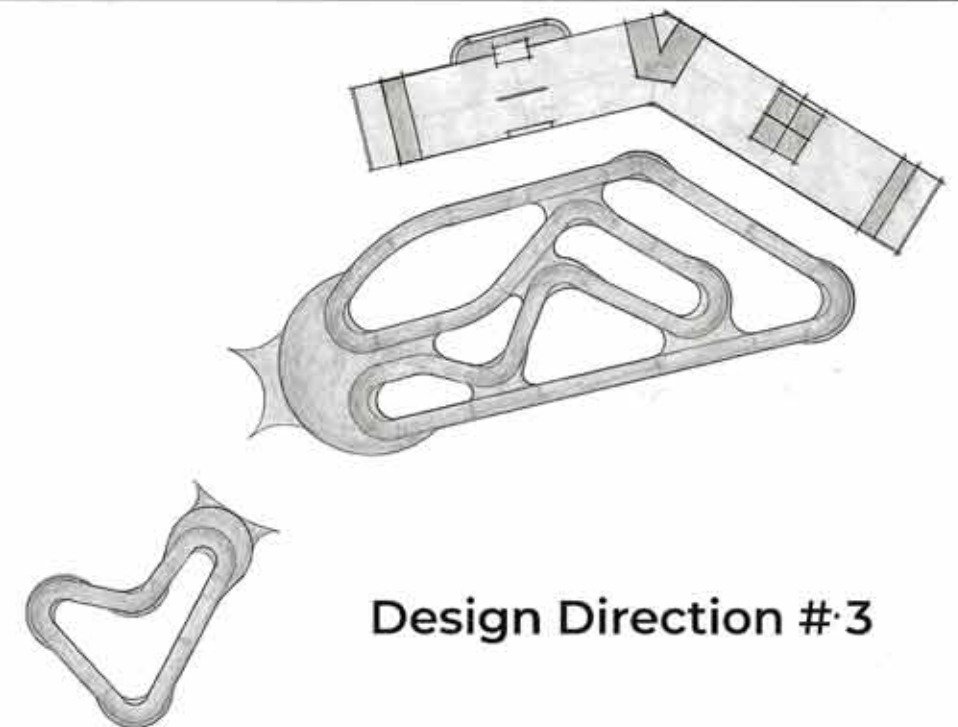
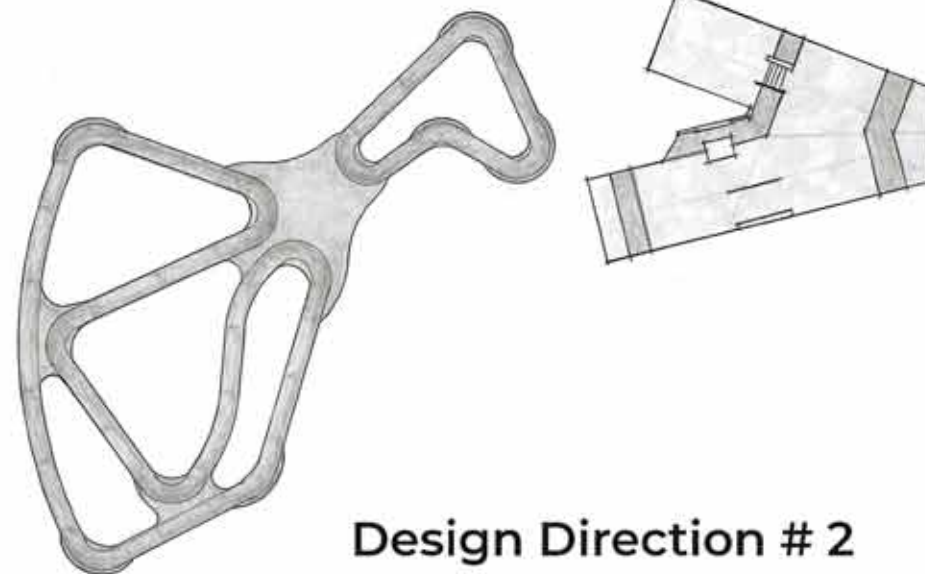
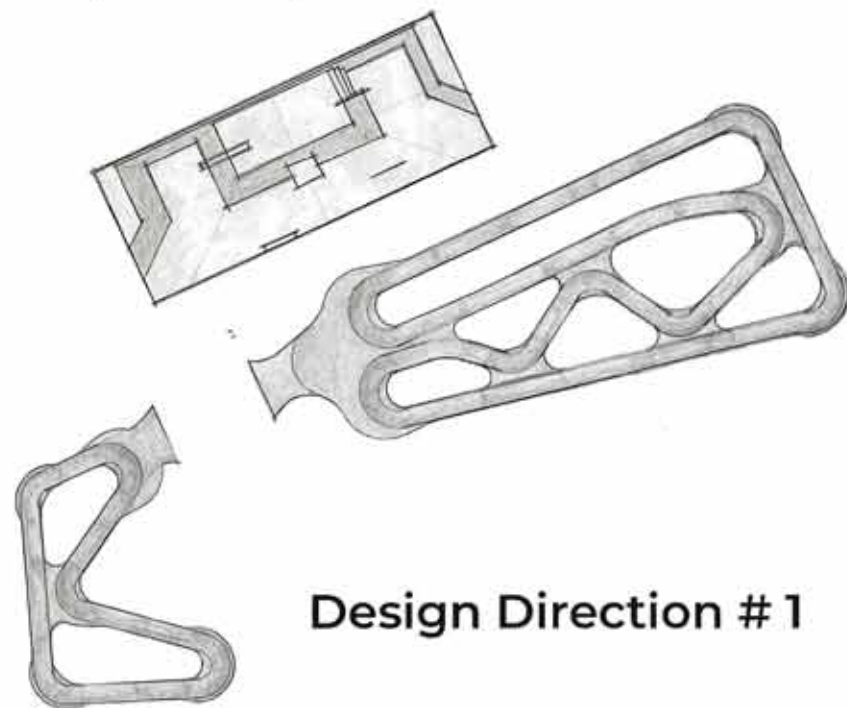

13

KIWANIS ALL WHEEL PARK

WORKSHOP FEEDBACK FORM

Name: [Redacted] Age: 26

Email: [Redacted]

1. What is your primary interest in this project?

- I'm a skateboarder I'm a BMX rider I'm a mountain biker I'm a roller skater / blader
 I'm a scooter rider I'm a parent / guardian or spectator
 Other (please specify) _____

2. How would you describe your skateboarding / riding ability?

- Beginner Intermediate Advanced I don't skate or ride

3. How often do you skate / ride?

- 3+ days a week 1-2 times a week 1-2 times a month I don't skate or ride

4. What part of the All Wheel Park interests you the most?

- Pump Track Skatepark

5. What's your favourite PUMP TRACK option, and why? Option #1 Option #2 Option #3

6. What's your favourite SKATEPARK option, and why? Option #1 Option #2 Option #3

7. Beyond the Pump Track and Skatepark facilities themselves, is there anything else you would like to see in the park? (i.e. seating / viewing spaces, landscaping, shade, washrooms, etc.)

8. General Comments. (use the adjacent box or back of this sheet if you need more space)

Better layout

Water fountain

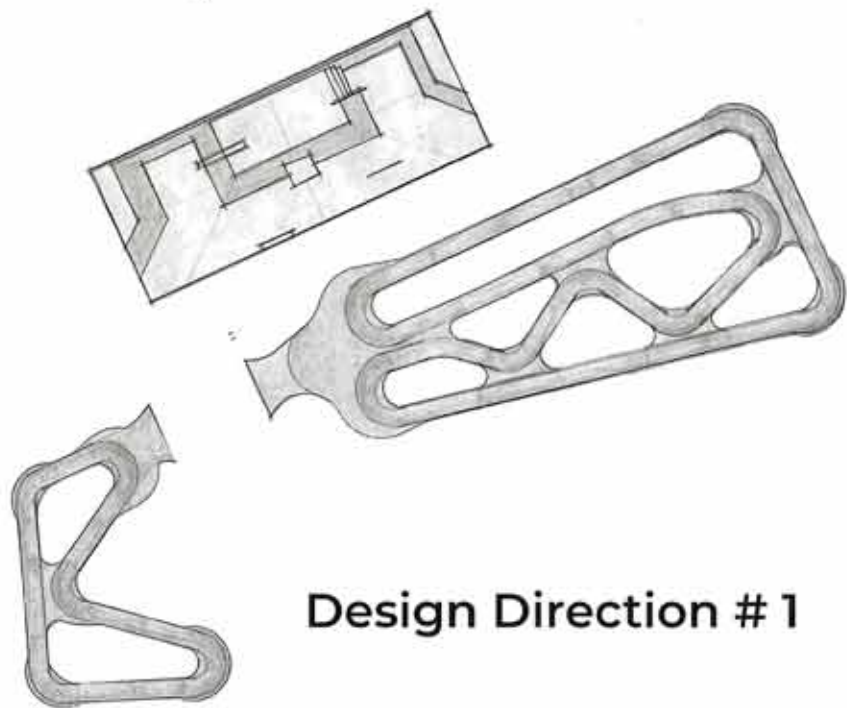

Design Direction # 1

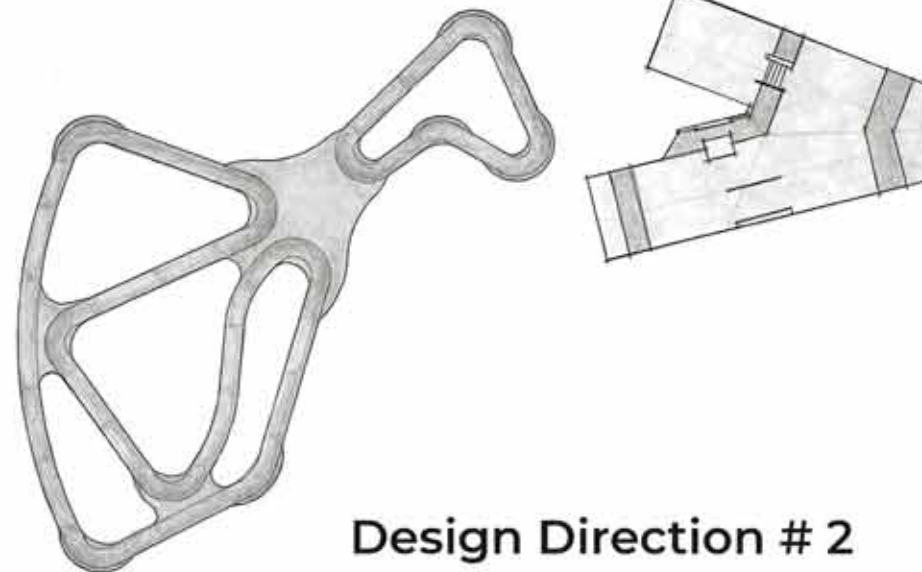

Design Direction # 2

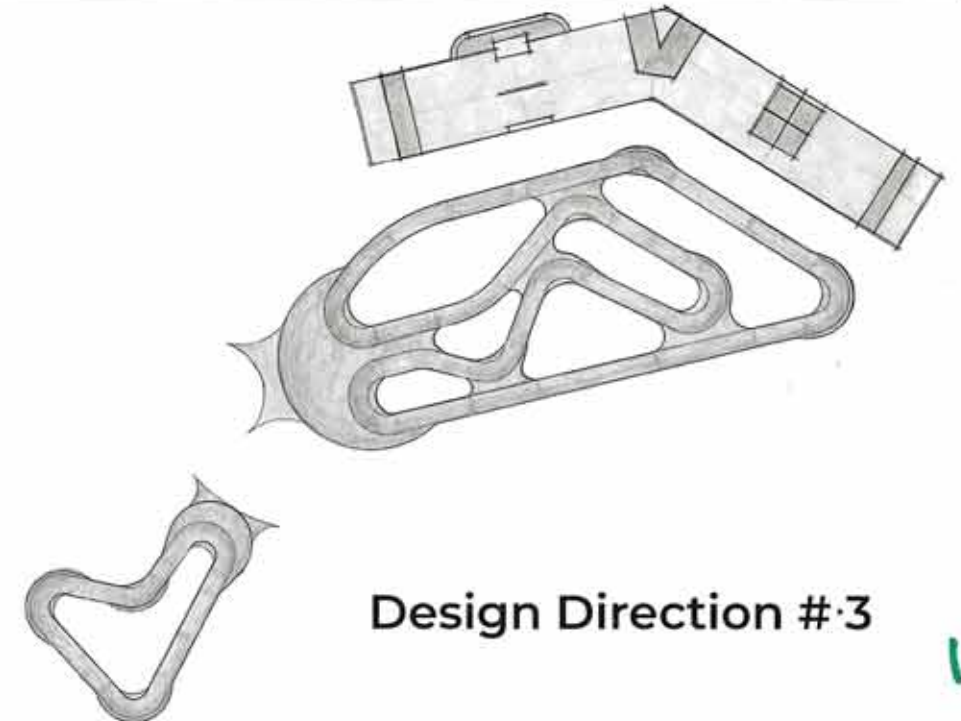

Design Direction # 3

14

KIWANIS ALL WHEEL PARK

WORKSHOP FEEDBACK FORM

Name: [Redacted] Age: 18

Email: [Redacted] com

1. What is your primary interest in this project?

- I'm a skateboarder I'm a BMX rider I'm a mountain biker I'm a roller skater / blader
 I'm a scooter rider I'm a parent / guardian or spectator
 Other (please specify) _____

2. How would you describe your skateboarding / riding ability?

- Beginner Intermediate Advanced I don't skate or ride

3. How often do you skate / ride?

- 3+ days a week 1-2 times a week 1-2 times a month I don't skate or ride

4. What part of the All Wheel Park interests you the most?

- Pump Track Skatepark

5. What's your favourite PUMP TRACK option, and why? Option #1 Option #2 Option #3

6. What's your favourite SKATEPARK option, and why? Option #1 Option #2 Option #3

best use of space to get more obstacles.
street section looking best

7. Beyond the Pump Track and Skatepark facilities themselves, is there anything else you would like to see in the park?
(i.e. seating / viewing spaces, landscaping, shade, washrooms, etc.)

down rails, ledges and a flame.

8. General Comments. (use the adjacent box or back of this sheet if you need more space)

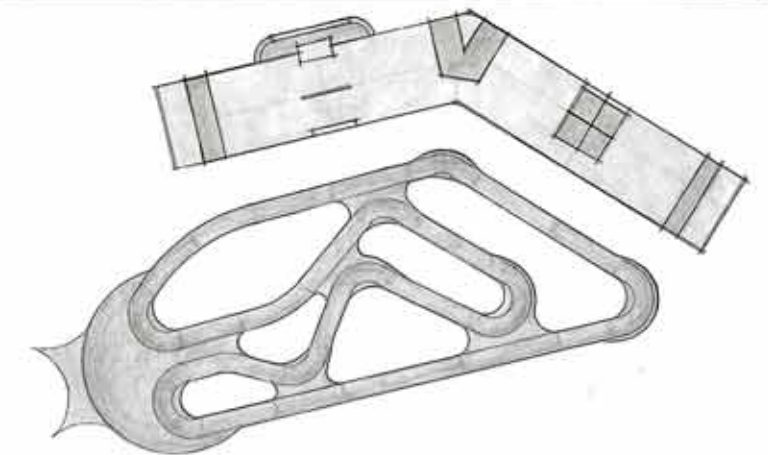
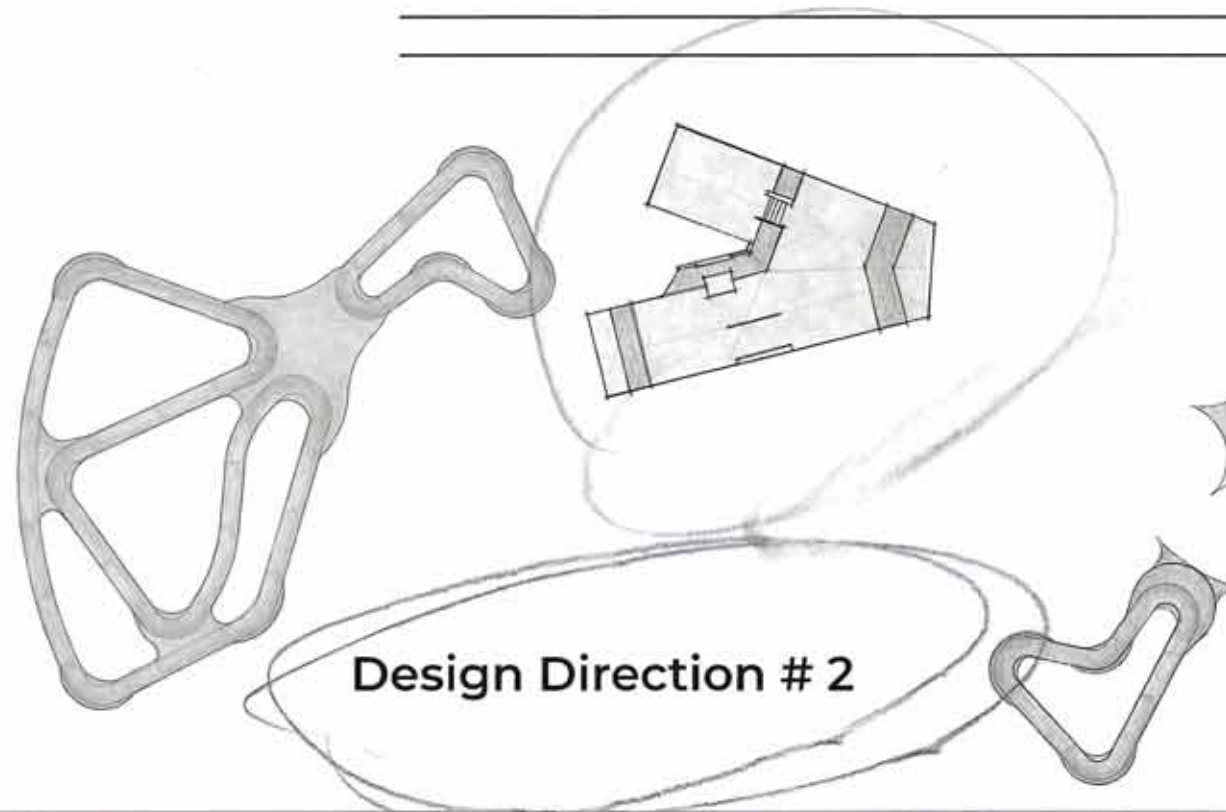
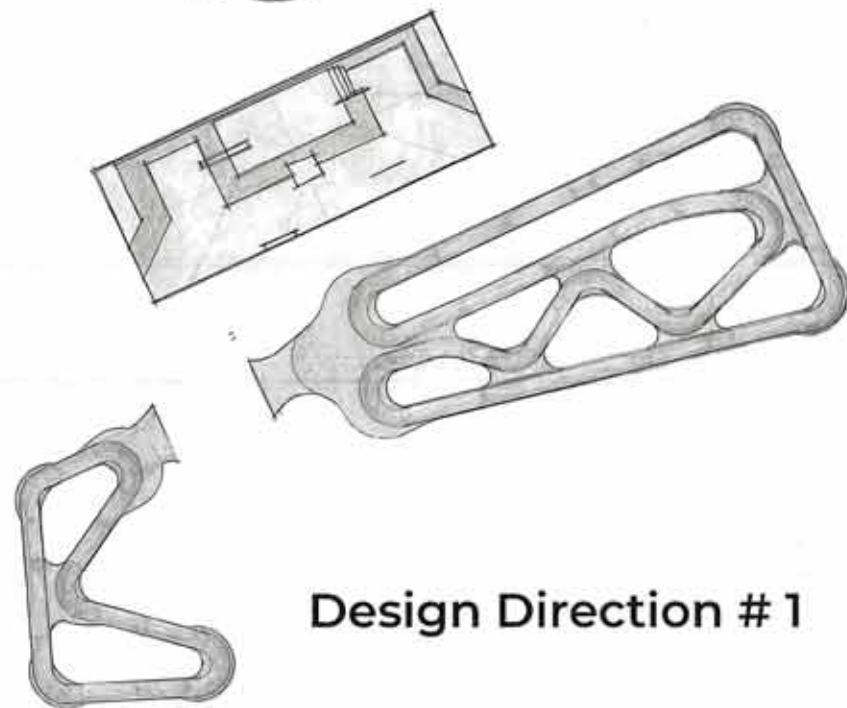

15

KIWANIS ALL WHEEL PARK

WORKSHOP FEEDBACK FORM

Name: [REDACTED] Age: 29
 Email: [REDACTED] .com

- What is your primary interest in this project?
 I'm a skateboarder I'm a BMX rider I'm a mountain biker I'm a roller skater / blader
 I'm a scooter rider I'm a parent / guardian or spectator
 Other (please specify) _____
- How would you describe your skateboarding / riding ability?
 Beginner Intermediate Advanced I don't skate or ride
- How often do you skate / ride?
 3+ days a week 1-2 times a week 1-2 times a month I don't skate or ride
- What part of the All Wheel Park interests you the most?
 Pump Track Skatepark

- What's your favourite PUMP TRACK option, and why? Option #1 Option #2 Option #3
*No JUNIOR - I DON'T LIKE PUMP TRACK - TOO MUCH PUMP TRACK
 - Where is the Bowl?*
- What's your favourite SKATEPARK option, and why? Option #1 Option #2 Option #3
*both good, but could be bigger, more ramps.
 Also would like a bowl, more transition*
- Beyond the Pump Track and Skatepark facilities themselves, is there anything else you would like to see in the park?
 (i.e. seating / viewing spaces, landscaping, shade, washrooms, etc.)
maybe some benches
- General Comments. (use the adjacent box or back of this sheet if you need more space)
*I would like to see more skateparks, less pump tracks.
 Also would like a bowl*

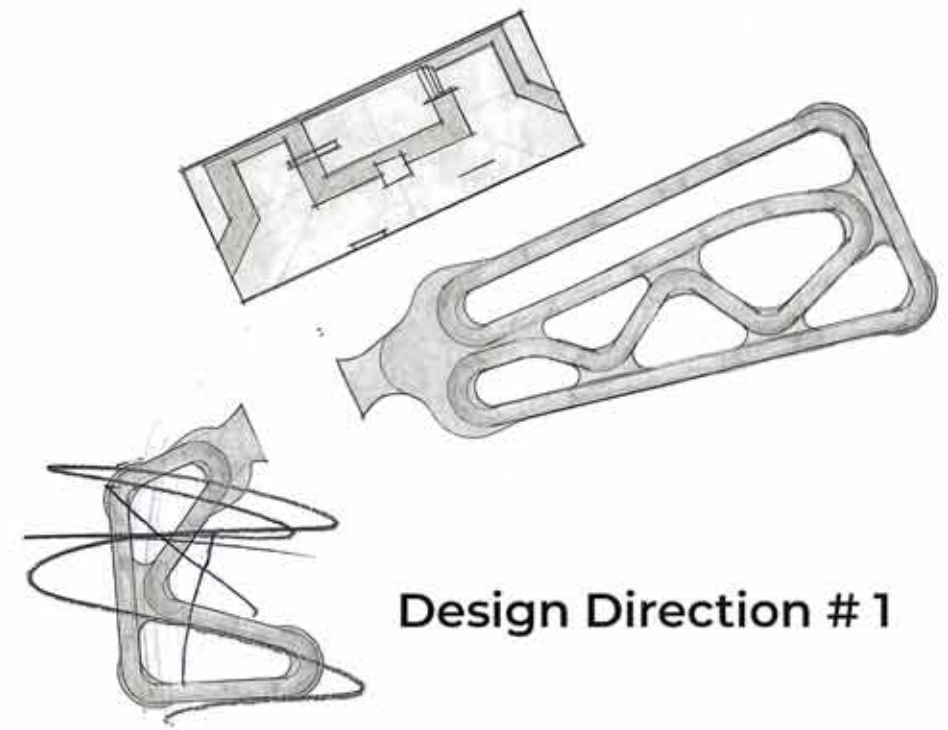

Design Direction #1

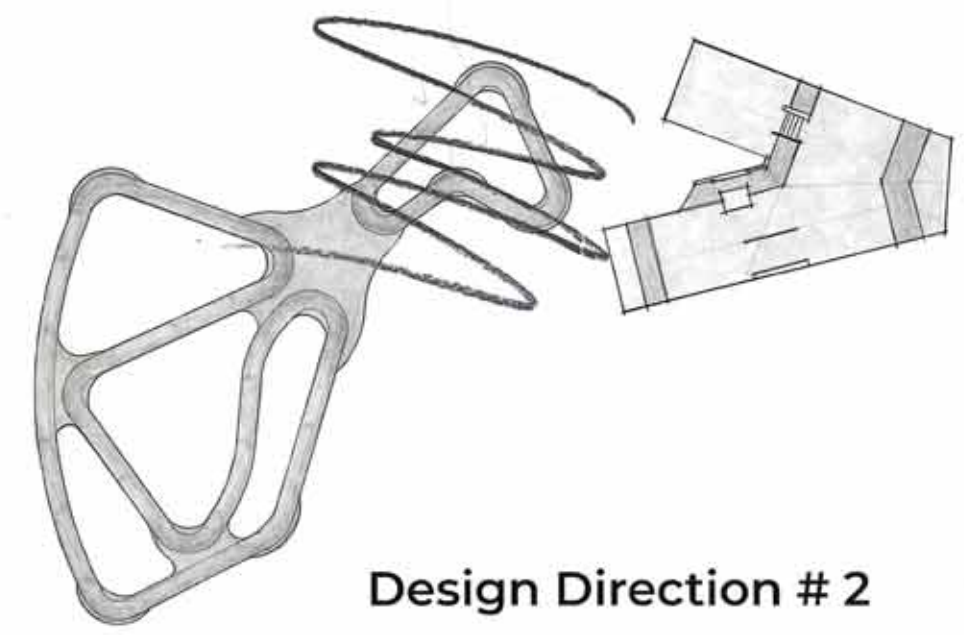

Design Direction #2

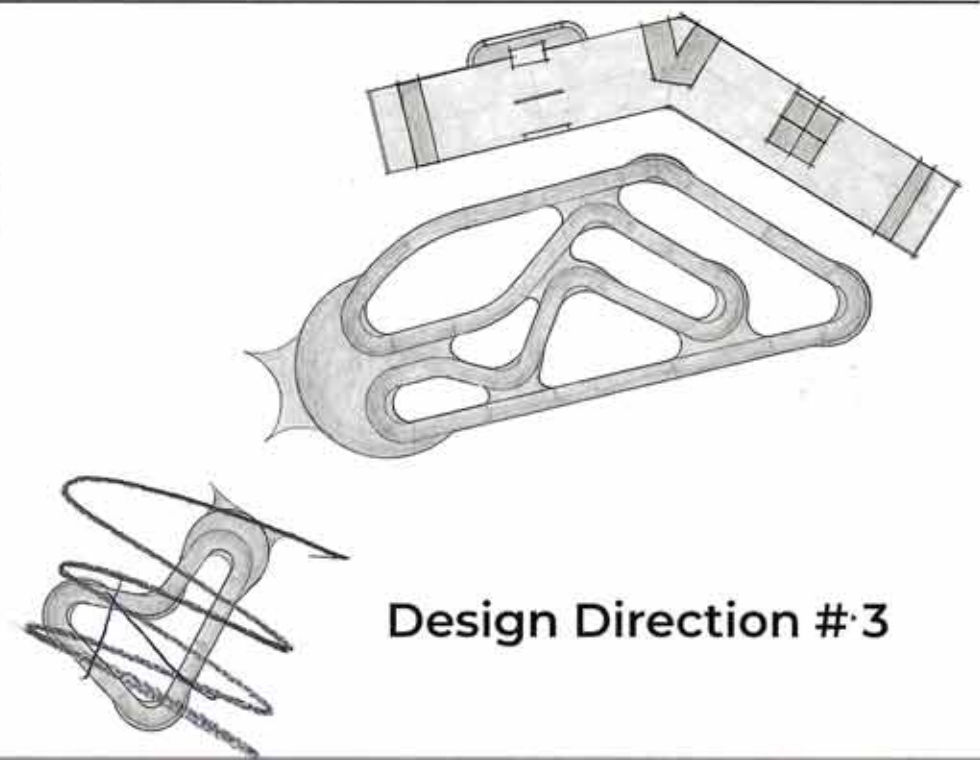

Design Direction #3

16

KIWANIS ALL WHEEL PARK

WORKSHOP FEEDBACK FORM

Name: [REDACTED]

Age: 47

Email: [REDACTED]

1. What is your primary interest in this project?

- I'm a skateboarder I'm a BMX rider I'm a mountain biker I'm a roller skater / blader
 I'm a scooter rider I'm a parent / guardian or spectator
 Other (please specify) _____

2. How would you describe your skateboarding / riding ability?

- Beginner Intermediate Advanced I don't skate or ride

3. How often do you skate / ride?

- 3+ days a week 1-2 times a week 1-2 times a month I don't skate or ride

4. What part of the All Wheel Park interests you the most?

- Pump Track Skatepark

5. What's your favourite PUMP TRACK option, and why? Option #1 Option #2 Option #3

I'M NOT IN FAVOR OF THIS MUCH PUMP-TRACK

6. What's your favourite SKATEPARK option, and why? Option #1 Option #2 Option #3 ?

THE INITIAL DESIGN/SPACE SEEMS SMALL

7. Beyond the Pump Track and Skatepark facilities themselves, is there anything else you would like to see in the park?
(i.e. seating / viewing spaces, landscaping, shade, washrooms, etc.)

SHADE

8. General Comments. (use the adjacent box or back of this sheet if you need more space)

TOO MUCH PUMP TRACK FOCUS - LACKING TRANSITION

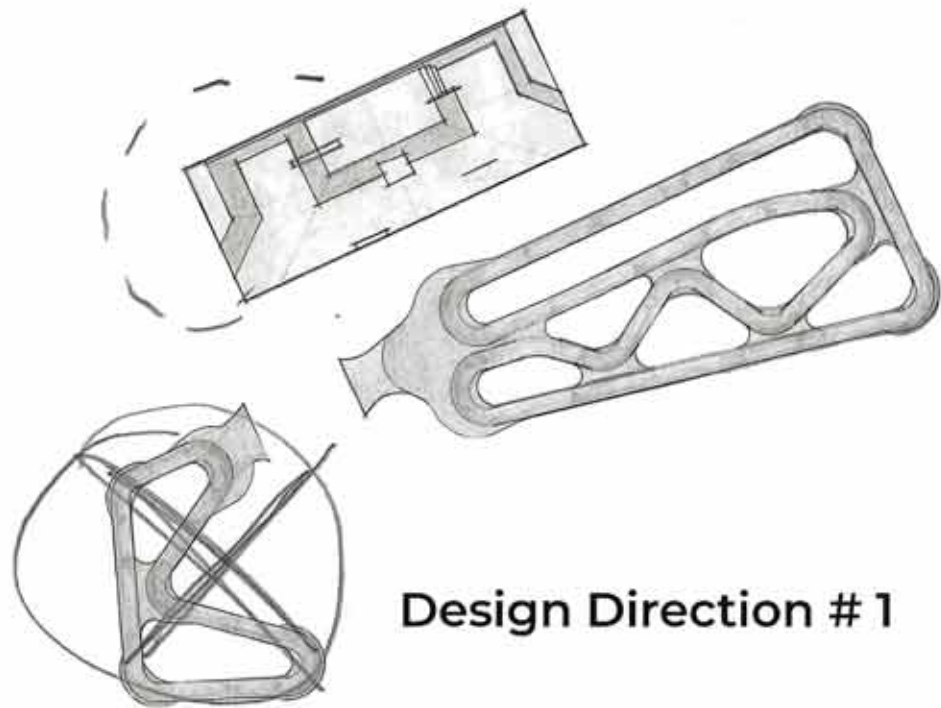

Design Direction #1

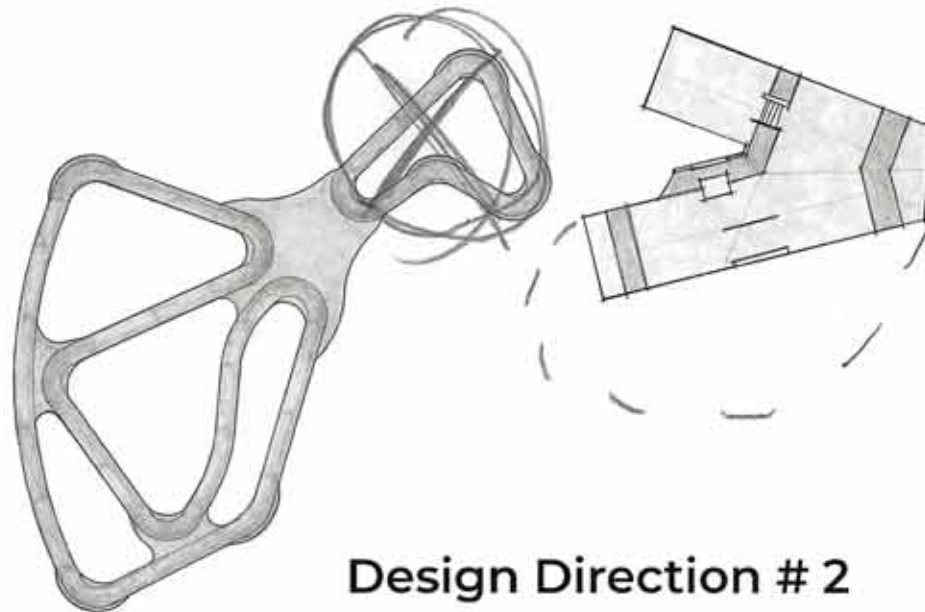

Design Direction #2

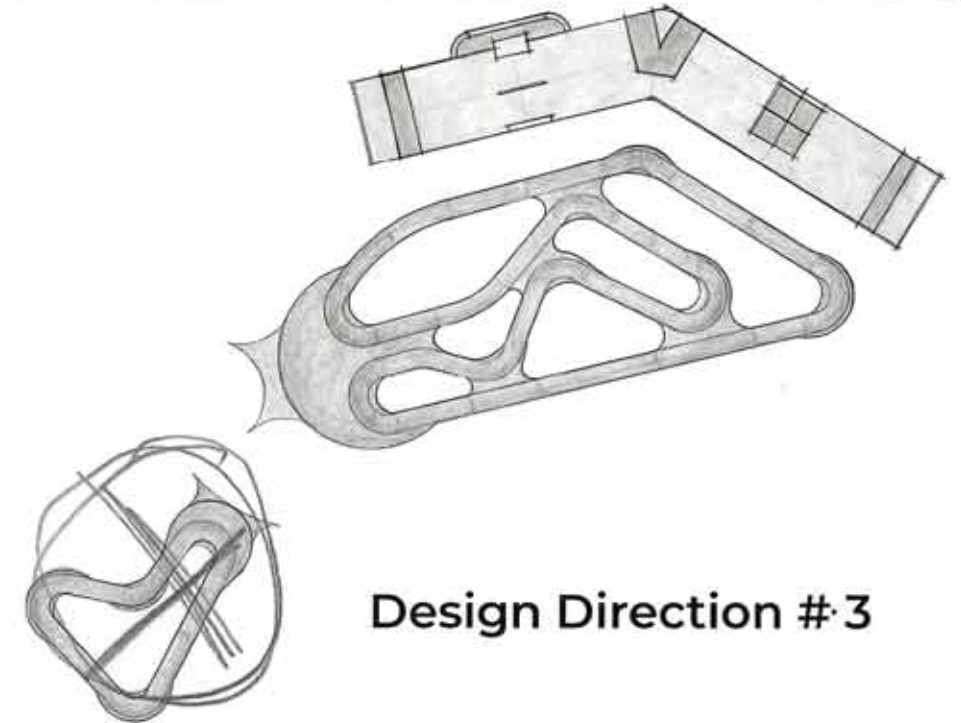

Design Direction #3

17

KIWANIS ALL WHEEL PARK

WORKSHOP FEEDBACK FORM

Name: [REDACTED]
 Email: [REDACTED]

Age: 56

1. What is your primary interest in this project?

- I'm a skateboarder
 I'm a BMX rider
 I'm a mountain biker
 I'm a roller skater / blader
 I'm a scooter rider
 I'm a parent / guardian or spectator
 Other (please specify) _____

2. How would you describe your skateboarding / riding ability?

- Beginner
 Intermediate
 Advanced
 I don't skate or ride

3. How often do you skate / ride?

- 3+ days a week
 1-2 times a week
 1-2 times a month
 I don't skate or ride

4. What part of the All Wheel Park interests you the most?

- Pump Track
 Skatepark

5. What's your favourite PUMP TRACK option, and why?
 Option #1
 Option #2
 Option #3

NO LIGHTS ON PUMP TRACK

6. What's your favourite SKATEPARK option, and why?
 Option #1
 Option #2
 Option #3

ELONGATED

7. Beyond the Pump Track and Skatepark facilities themselves, is there anything else you would like to see in the park?
 (i.e. seating / viewing spaces, landscaping, shade, washrooms, etc.)

TREES / SOLAR PANELS

8. General Comments. (use the adjacent box or back of this sheet if you need more space)

ROOM FOR EXPANSION

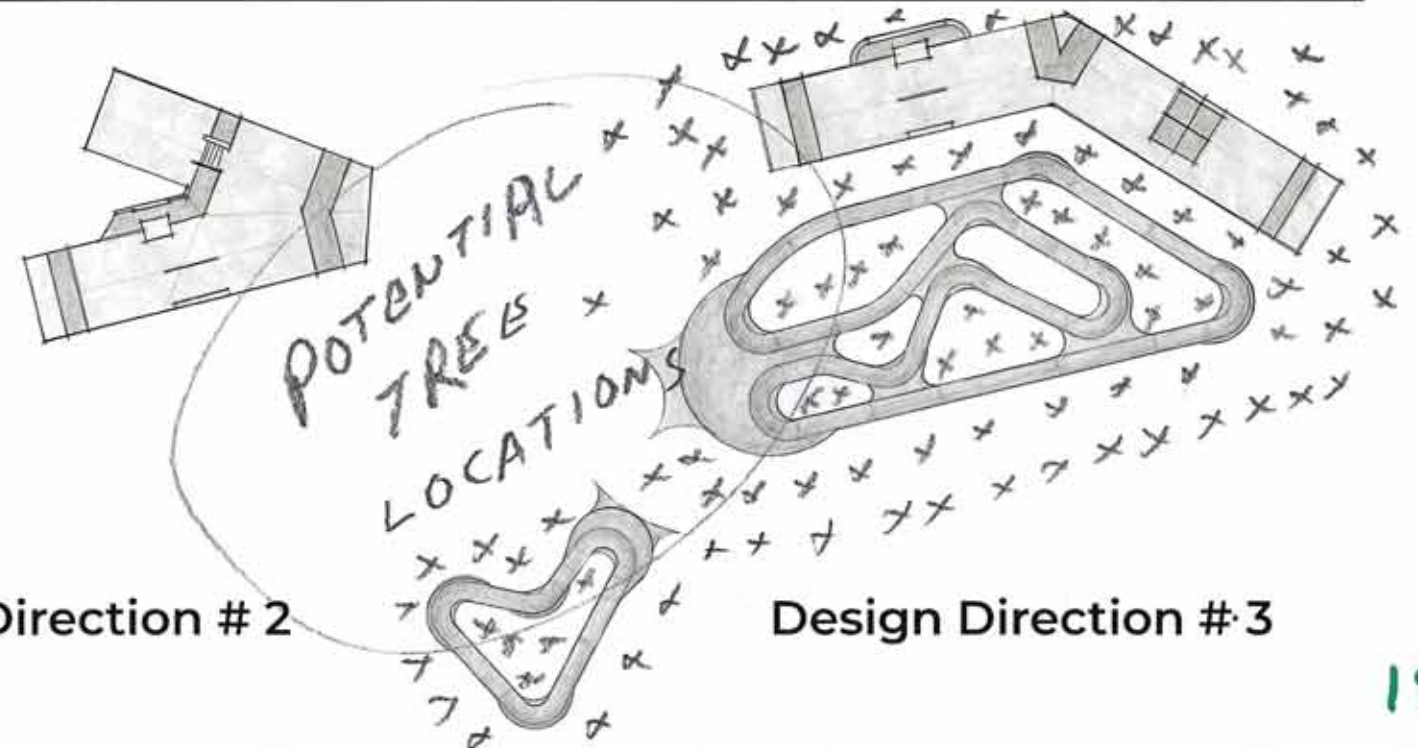
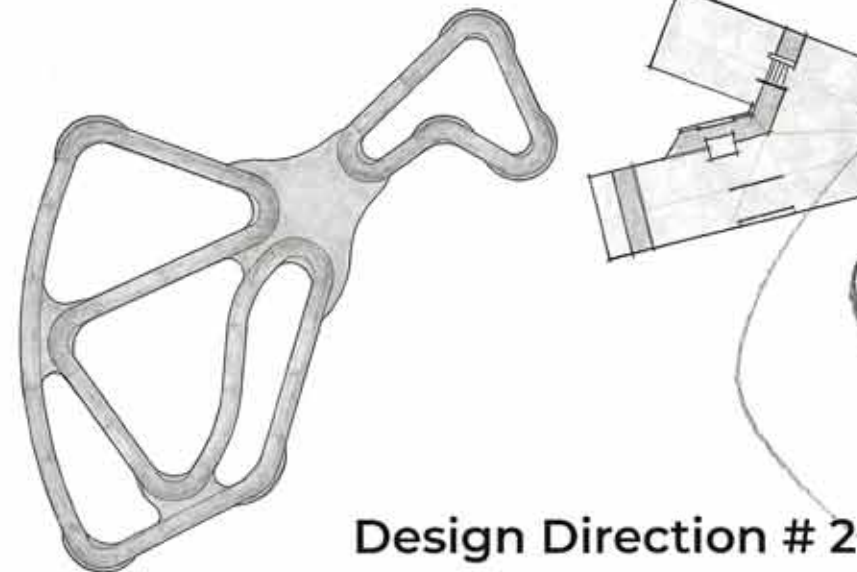
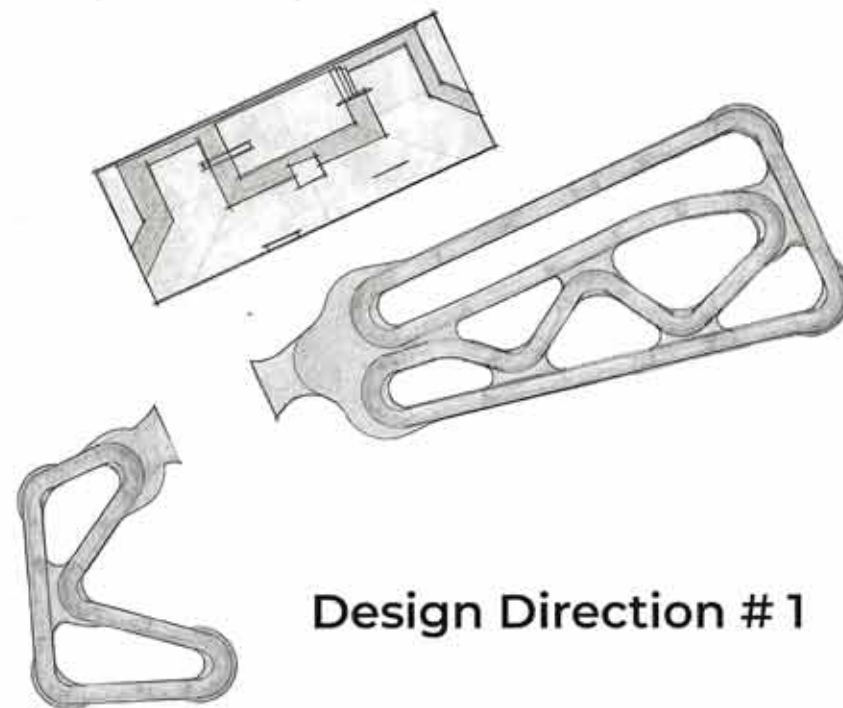

18

KIWANIS ALL WHEEL PARK

WORKSHOP FEEDBACK FORM

Name: [Redacted] Age: 27

Email: [Redacted]

1. What is your primary interest in this project?

- I'm a skateboarder I'm a BMX rider I'm a mountain biker I'm a roller skater / blader
 I'm a scooter rider I'm a parent / guardian or spectator
 Other (please specify) _____

2. How would you describe your skateboarding / riding ability?

- Beginner Intermediate Advanced I don't skate or ride

3. How often do you skate / ride?

- 3+ days a week 1-2 times a week 1-2 times a month I don't skate or ride

4. What part of the All Wheel Park interests you the most?

- Pump Track Skatepark

5. What's your favourite PUMP TRACK option, and why? Option #1 Option #2 Option #3

I think any of these pump tracks would be perfect

6. What's your favourite SKATEPARK option, and why? Option #1 Option #2 Option #3

~~that~~ I kinda need a bigger and more in person view of the size of the skate park

7. Beyond the Pump Track and Skatepark facilities themselves, is there anything else you would like to see in the park? (i.e. seating / viewing spaces, landscaping, shade, washrooms, etc.)

a bigger stair set at least 8 and above

8. General Comments. (use the adjacent box or back of this sheet if you need more space)

as an advanced bmx rider I have comments on the height of the rails and how big the quarters transition are. Some bmx

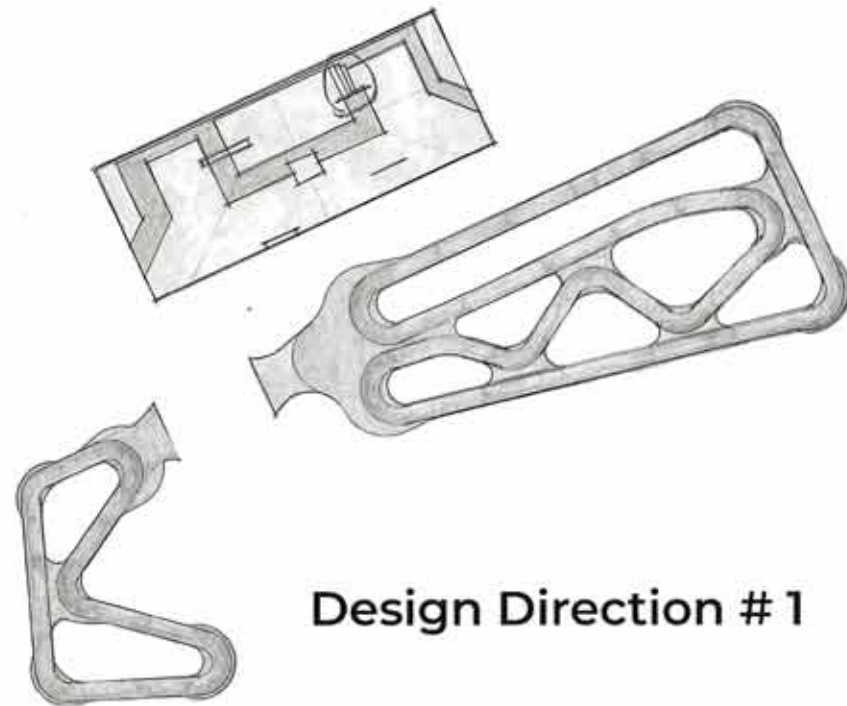

Design Direction #1

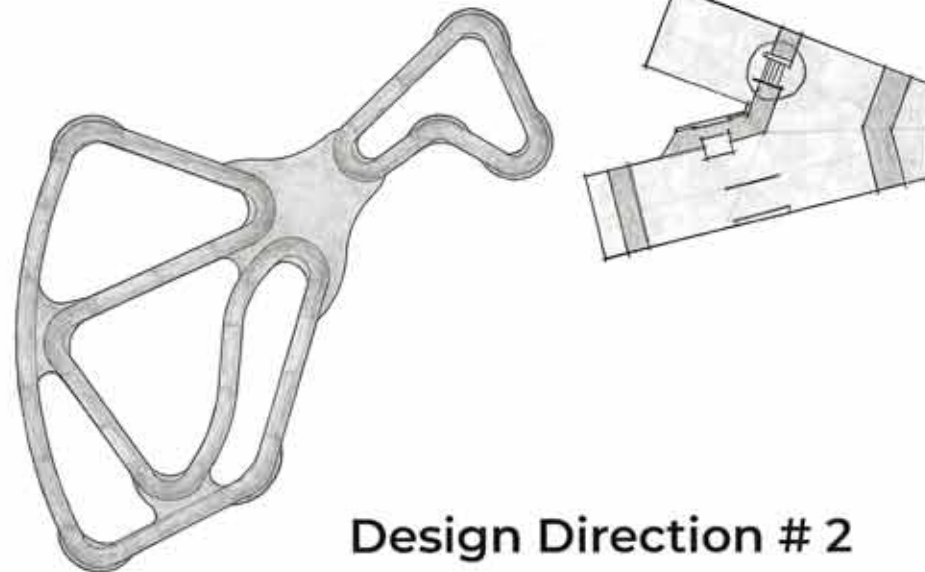

Design Direction #2

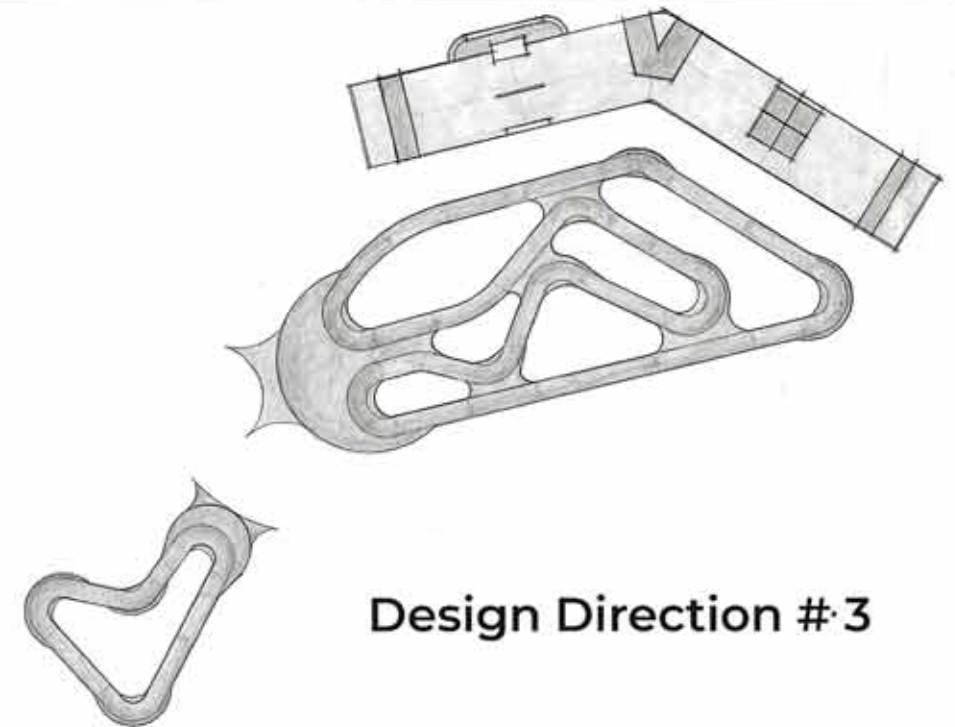

Design Direction #3

19

KIWANIS ALL WHEEL PARK

WORKSHOP FEEDBACK FORM

Name: [Redacted]
Email: [Redacted]

Age: 30

1. What is your primary interest in this project?

- I'm a skateboarder I'm a BMX rider I'm a mountain biker I'm a roller skater / blader
 I'm a scooter rider I'm a parent / guardian or spectator
 Other (please specify) skate OR Die!!!

2. How would you describe your skateboarding / riding ability?

- Beginner Intermediate Advanced I don't skate or ride

3. How often do you skate / ride?

- 3+ days a week 1-2 times a week 1-2 times a month I don't skate or ride

4. What part of the All Wheel Park interests you the most?

- Pump Track Skatepark

5. What's your favourite PUMP TRACK option, and why? Option #1 Option #2 Option #3

6. What's your favourite SKATEPARK option, and why? Option #1 Option #2 Option #3

7. Beyond the Pump Track and Skatepark facilities themselves, is there anything else you would like to see in the park?
(i.e. seating / viewing spaces, landscaping, shade, washrooms, etc.)

Please pay respects to the 1st Nation's land we are ON!

8. General Comments. (use the adjacent box or back of this sheet if you need more space)

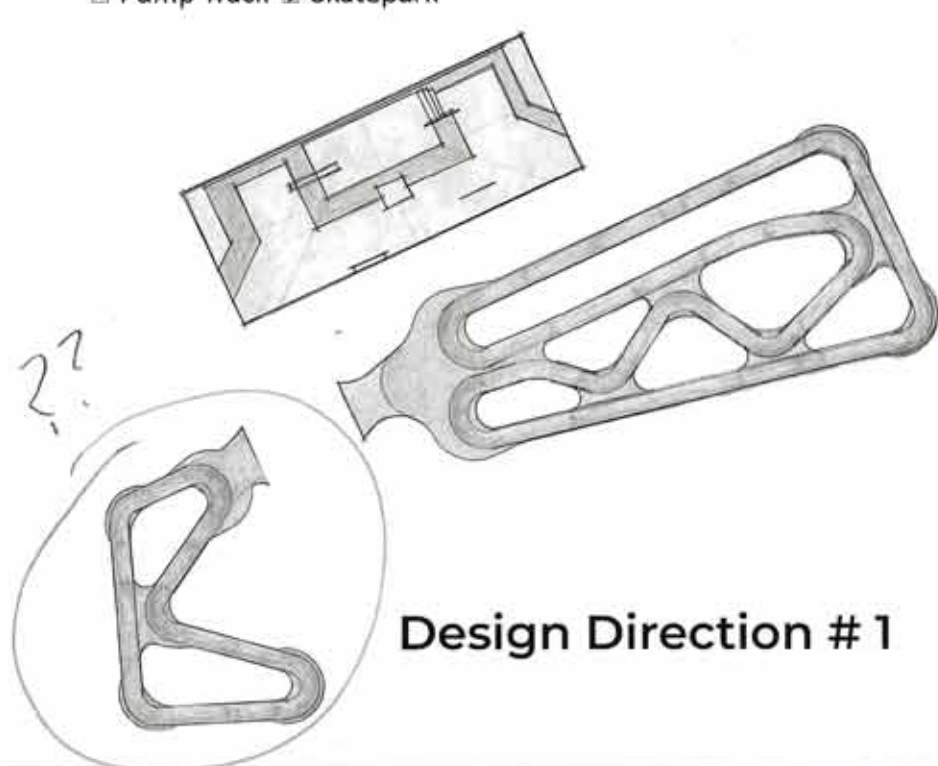

Design Direction #1

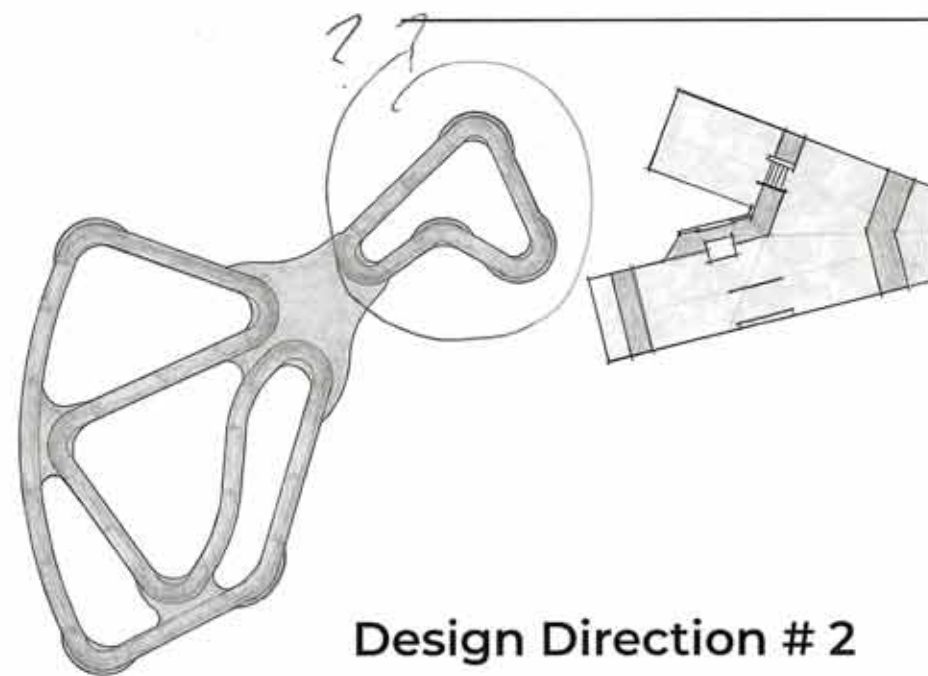

Design Direction #2

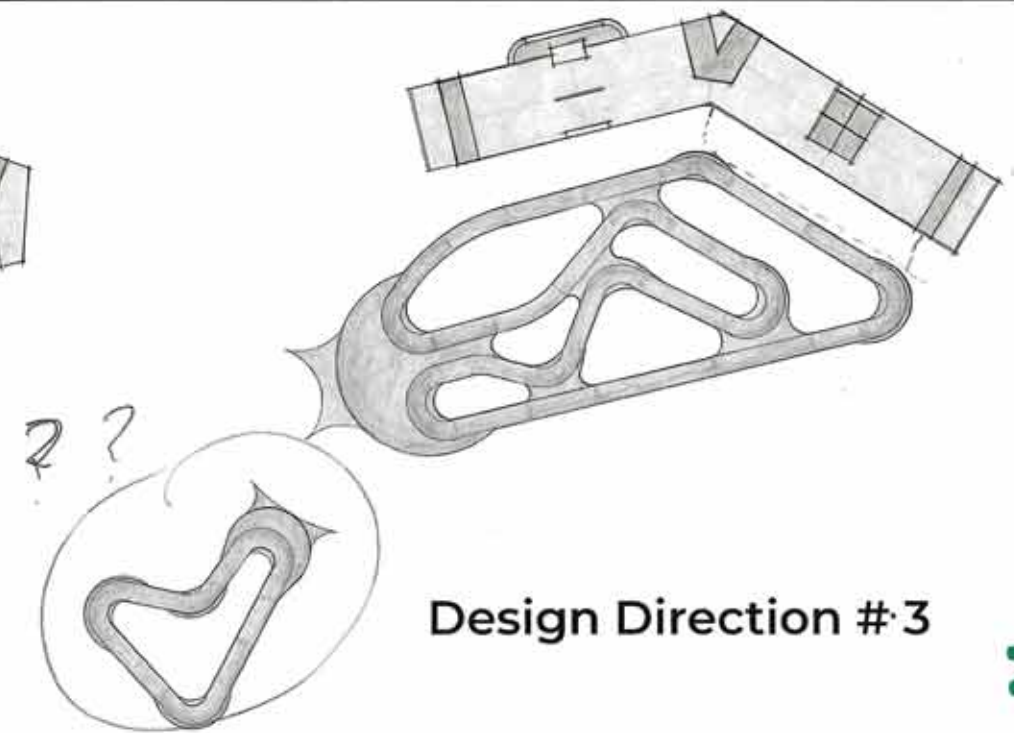

Design Direction #3

20

KIWANIS ALL WHEEL PARK

WORKSHOP FEEDBACK FORM

Name: [REDACTED]
 Email: [REDACTED]

Age: 47

1. What is your primary interest in this project?

- I'm a skateboarder
 I'm a BMX rider
 I'm a mountain biker
 I'm a roller skater / blader
 I'm a scooter rider
 I'm a parent / guardian or spectator
 Other (please specify) Observer (getting old!)

2. How would you describe your skateboarding / riding ability?

- Beginner
 Intermediate
 Advanced
 I don't skate or ride

3. How often do you skate / ride?

- 3+ days a week
 1-2 times a week
 1-2 times a month
 I don't skate or ride

4. What part of the All Wheel Park interests you the most?

- Pump Track
 Skatepark

50% 50%

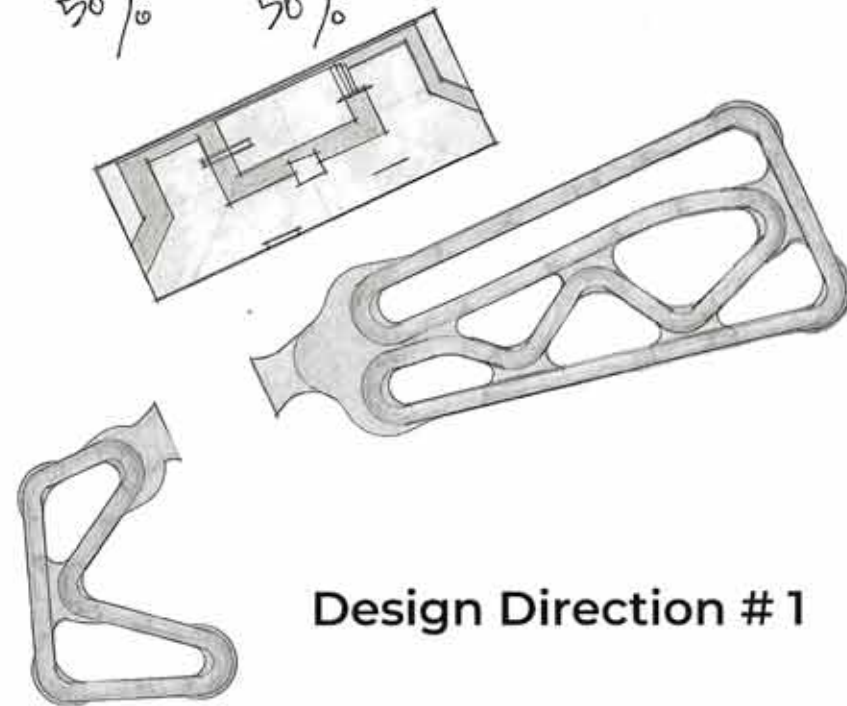

Design Direction #1

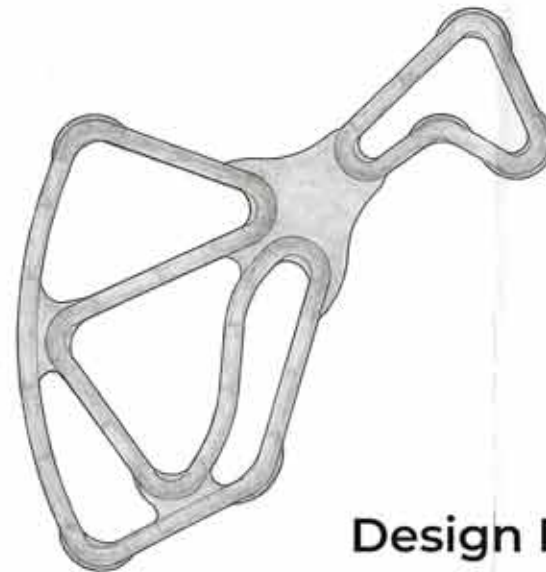

Design Direction #2

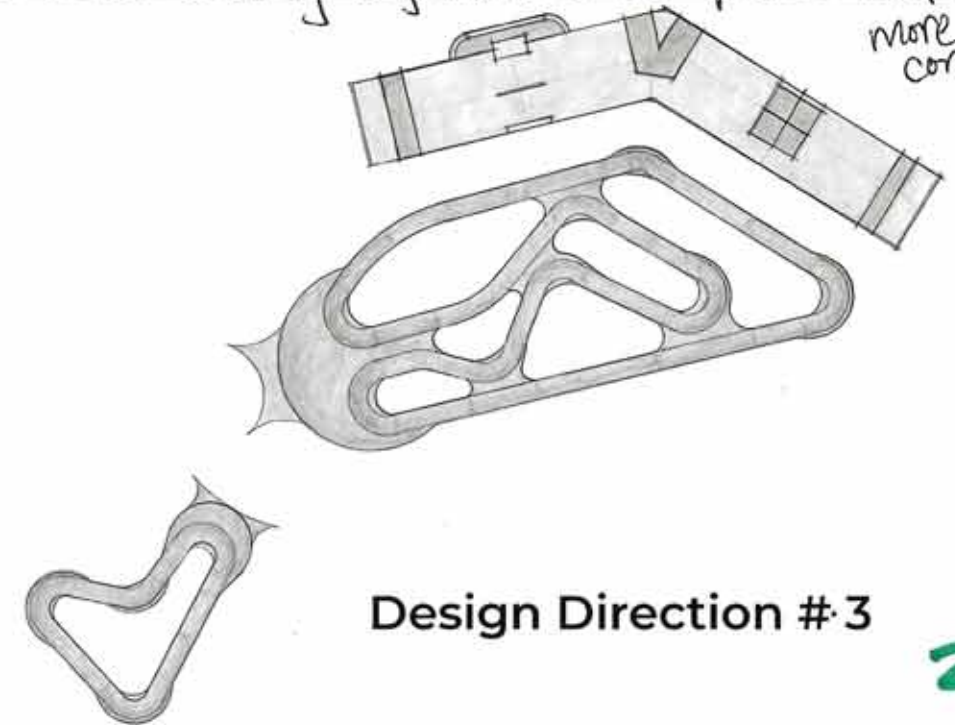

Design Direction #3

more comments on back →

21

5. What's your favourite PUMP TRACK option, and why? Option #1 Option #2 Option #3

I like the space between track runs - having more distance would give more comfortability for people to feel safer from interaction with each other

6. What's your favourite SKATEPARK option, and why? Option #1 Option #2 Option #3

I like the elevated plaza/park for a feature to those who aren't using but passing by.

7. Beyond the Pump Track and Skatepark facilities themselves, is there anything else you would like to see in the park? (i.e. seating / viewing spaces, landscaping, shade, washrooms, etc.)

Shade for sure - what future options are being considered for competitions, events, concerts etc
How has wind been factored into design of landscaping in adjacent areas?

8. General Comments. (use the adjacent box or back of this sheet if you need more space)

Looking forward to seeing this completed. Be careful of how you select the earthworks contractor and make sure you build in some contingency. Consider looking beyond local for quotes. Keeps pencils sharp!

Lighting -
For lighting, take into consideration the lake view conflict as well as what light pollution will it be creating.
What other lighting alternatives can be explored?

Drainage -
What soil investigations have been completed to know what drainage capacity will be?

KIWANIS ALL WHEEL PARK

WORKSHOP FEEDBACK FORM

Name: [REDACTED] Age: 36

Email: [REDACTED]

1. What is your primary interest in this project?

- I'm a skateboarder I'm a BMX rider I'm a mountain biker I'm a roller skater / blader
 I'm a scooter rider I'm a parent / guardian or spectator
 Other (please specify) _____

2. How would you describe your skateboarding / riding ability?

- Beginner Intermediate Advanced I don't skate or ride

3. How often do you skate / ride?

- 3+ days a week 1-2 times a week 1-2 times a month I don't skate or ride

4. What part of the All Wheel Park interests you the most?

- Pump Track Skatepark

5. What's your favourite PUMP TRACK option, and why? Option #1 Option #2 Option #3

jr. track
#1 for the jr. track. Excited for a family friendly track that allows for kids to progress as they age. *for advanced*

6. What's your favourite SKATEPARK option, and why? Option #1 Option #2 Option #3

7. Beyond the Pump Track and Skatepark facilities themselves, is there anything else you would like to see in the park? (i.e. seating / viewing spaces, landscaping, shade, washrooms, etc.)

shade + washrooms, water bottle refill station

8. General Comments. (use the adjacent box or back of this sheet if you need more space)

lights on the pump track. So excited for velosections to be involved. Every other pump track we've been at the pump track is very busy so the more space / longer pump track the better.

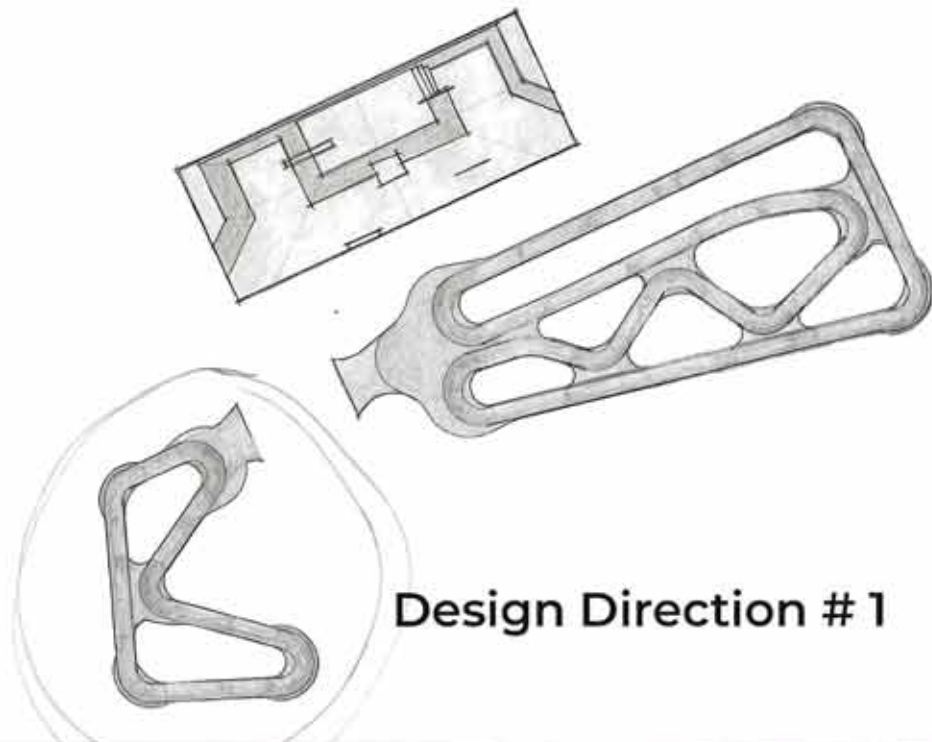

Design Direction # 1

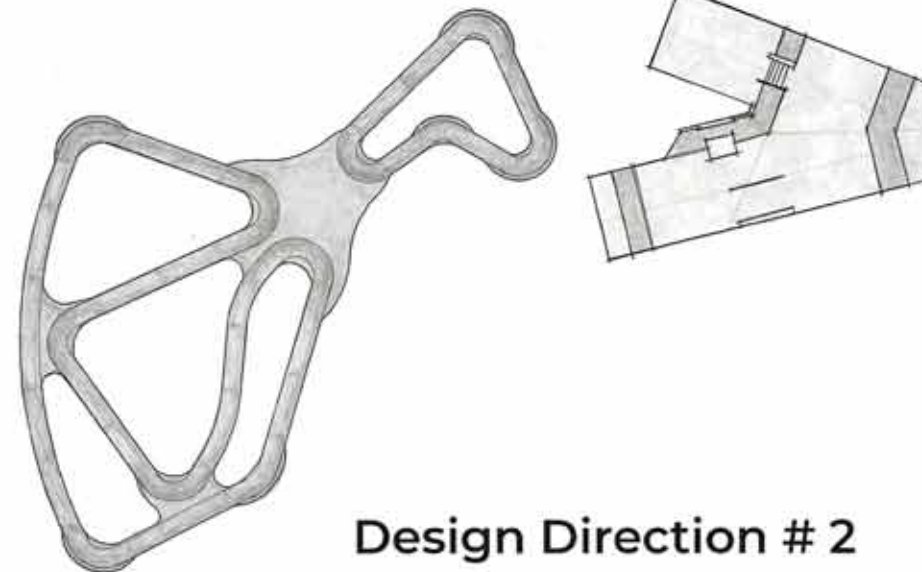

Design Direction # 2

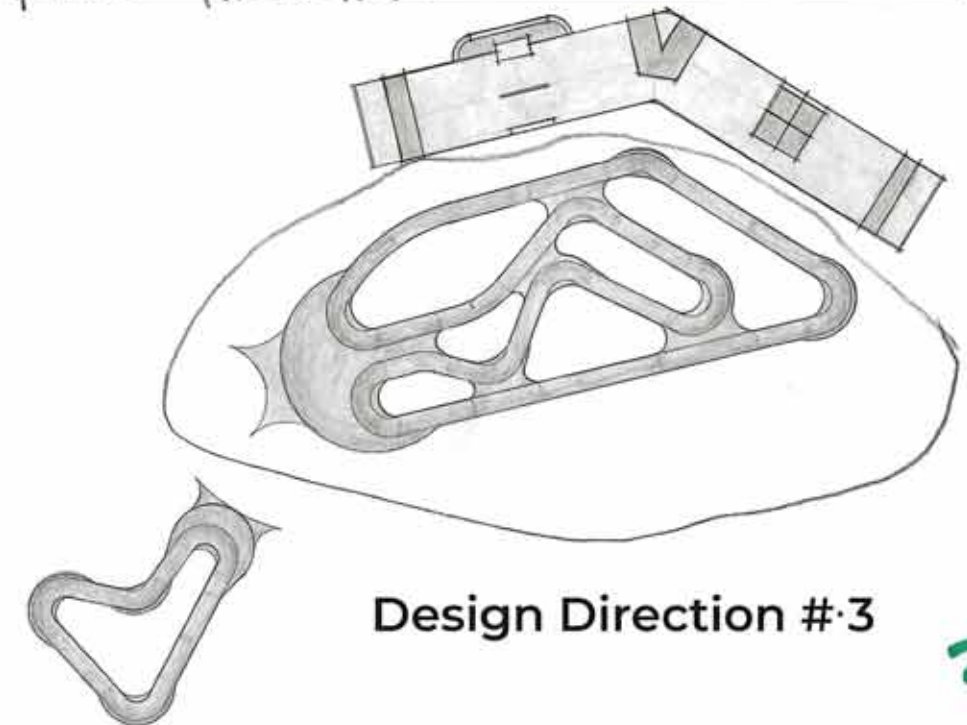

Design Direction #3

22

KIWANIS ALL WHEEL PARK

WORKSHOP FEEDBACK FORM

Name: [Redacted]
Email: [Redacted]

Age: 47

1. What is your primary interest in this project?
 I'm a skateboarder I'm a BMX rider I'm a mountain biker I'm a roller skater / blader
 I'm a scooter rider I'm a parent / guardian or spectator
 Other (please specify) _____
2. How would you describe your skateboarding / riding ability?
 Beginner Intermediate Advanced I don't skate or ride
3. How often do you skate / ride?
 3+ days a week 1-2 times a week 1-2 times a month I don't skate or ride
4. What part of the All Wheel Park interests you the most?
 Pump Track Skatepark

5. What's your favourite PUMP TRACK option, and why? Option #1 Option #2 Option #3
Very good flow.

6. What's your favourite SKATEPARK option, and why? Option #1 Option #2 Option #3

7. Beyond the Pump Track and Skatepark facilities themselves, is there anything else you would like to see in the park?
(i.e. seating / viewing spaces, landscaping, shade, washrooms, etc.)
Washrooms.

8. General Comments. (use the adjacent box or back of this sheet if you need more space)

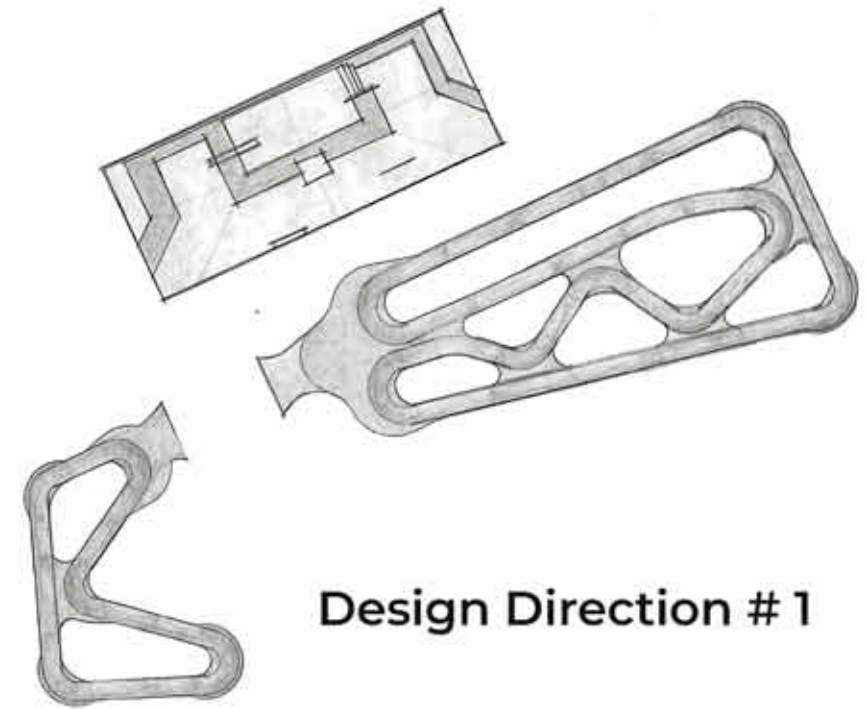

Design Direction # 1

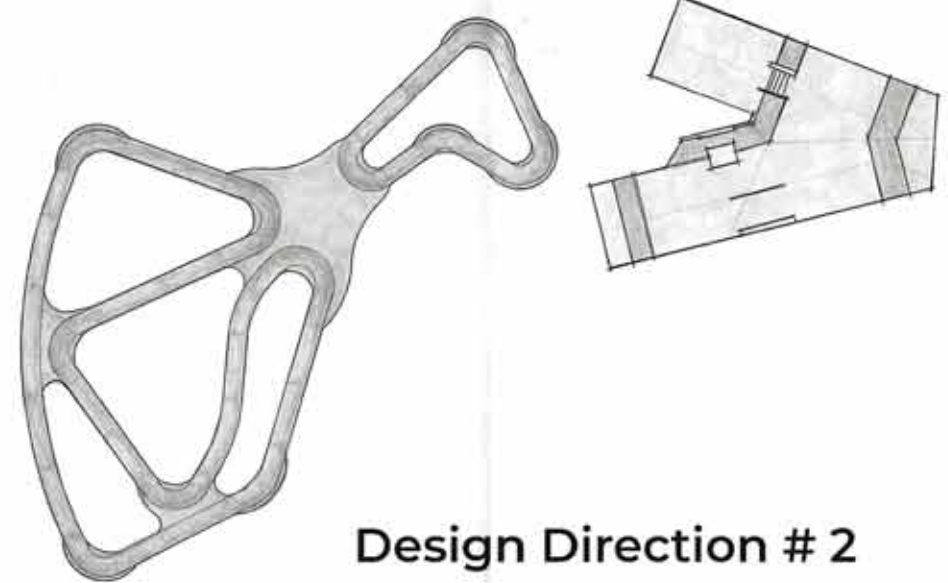

Design Direction # 2

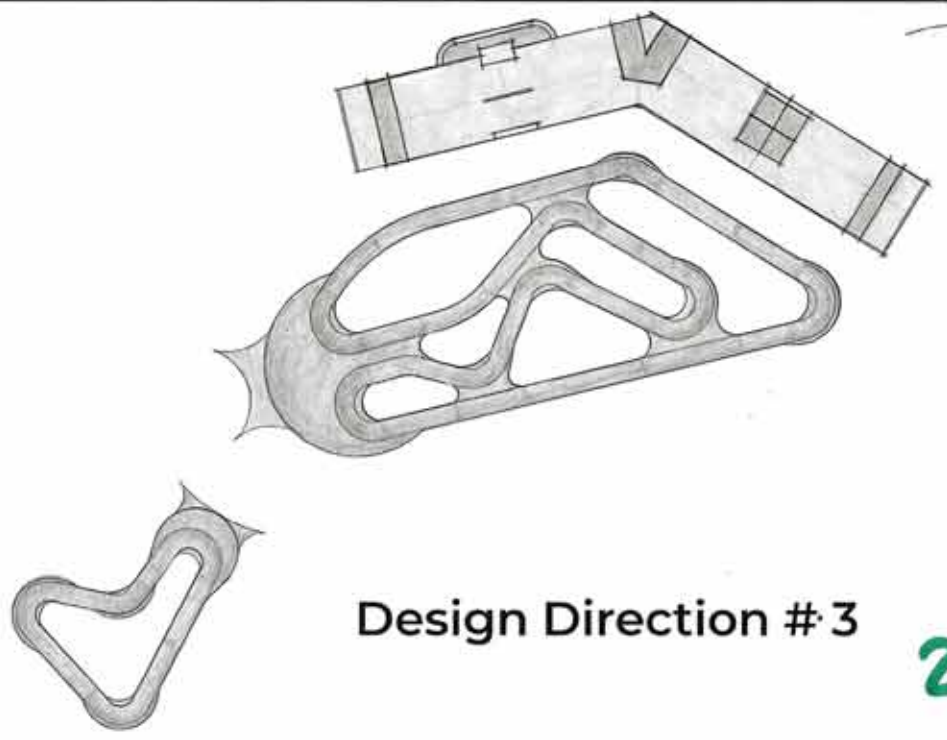

Design Direction # 3

23

KIWANIS ALL WHEEL PARK

WORKSHOP FEEDBACK FORM

Name: [Redacted] Age: 12

Email: [Redacted]

1. What is your primary interest in this project?

- I'm a skateboarder I'm a BMX rider I'm a mountain biker I'm a roller skater / blader
 I'm a scooter rider I'm a parent / guardian or spectator
 Other (please specify) _____

2. How would you describe your skateboarding / riding ability?

- Beginner Intermediate Advanced I don't skate or ride

3. How often do you skate / ride?

- 3+ days a week 1-2 times a week 1-2 times a month I don't skate or ride

4. What part of the All Wheel Park interests you the most?

- Pump Track Skatepark

5. What's your favourite PUMP TRACK option, and why? Option #1 Option #2 Option #3

I like all the twist and turns. It also looks like it has a good flow.

6. What's your favourite SKATEPARK option, and why? Option #1 Option #2 Option #3

I like all the different obstacles and it also looks like a good flow

7. Beyond the Pump Track and Skatepark facilities themselves, is there anything else you would like to see in the park? (i.e. seating / viewing spaces, landscaping, shade, washrooms, etc.)

one problem with lots of skate parks is that there is no shade. so I would like to see lots of shade

8. General Comments. (use the adjacent box or back of this sheet if you need more space)

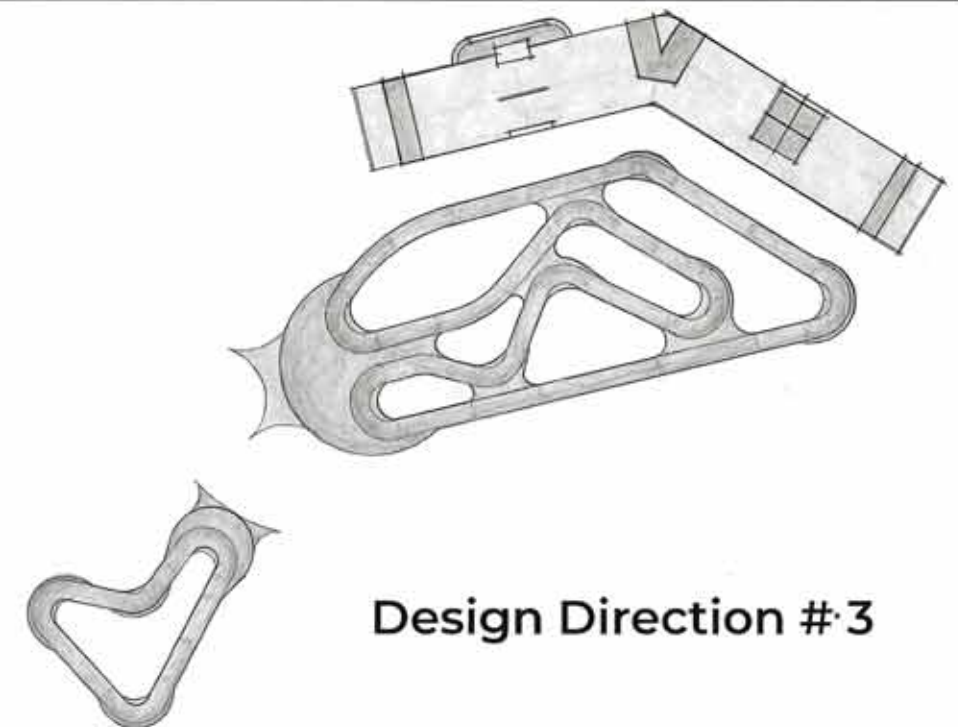
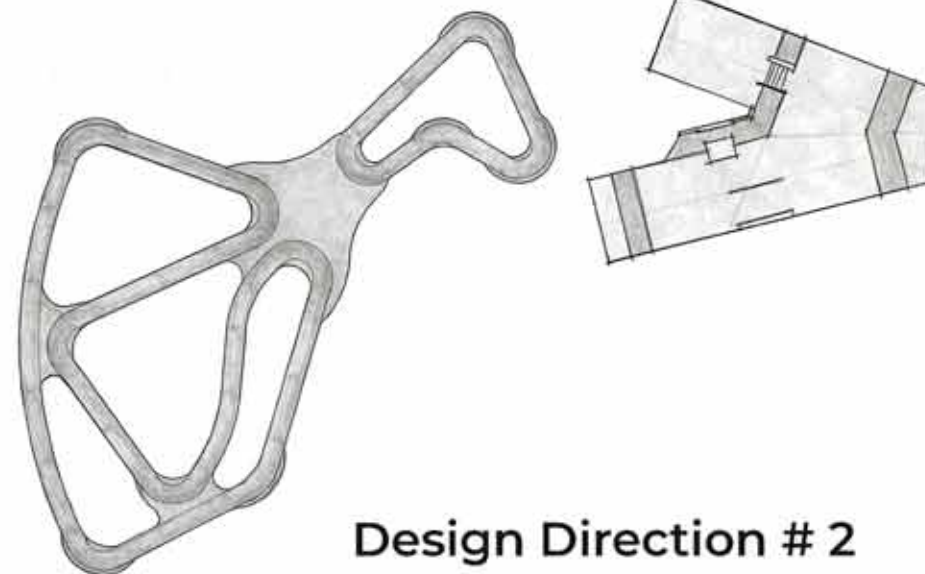
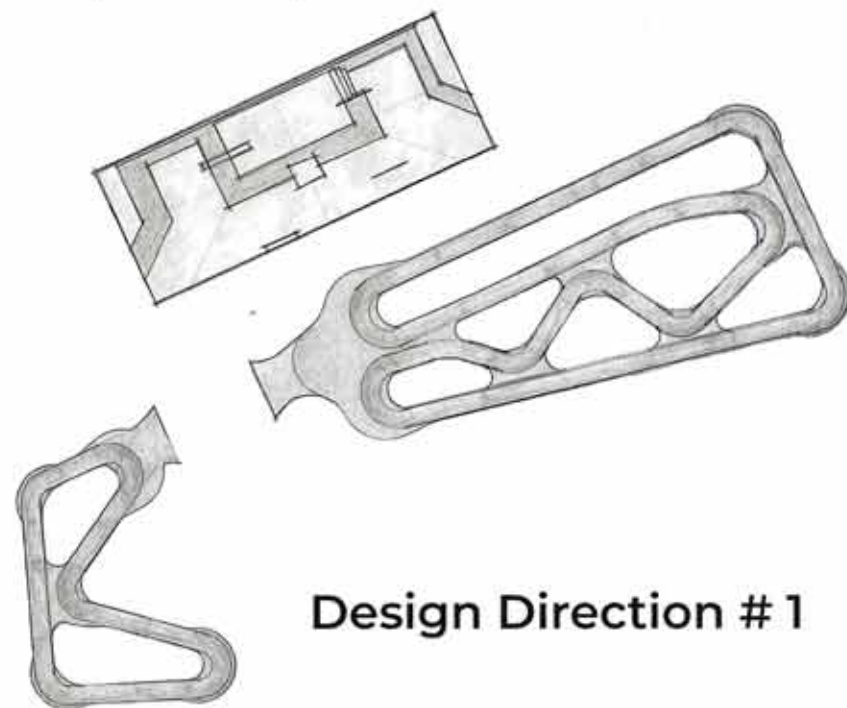

24



2

KIWANIS ALL WHEEL PARK

WORKSHOP FEEDBACK FORM

Name: [Redacted] Age: 7

parent Email: [Redacted]

1. What is your primary interest in this project?

- I'm a skateboarder I'm a BMX rider I'm a mountain biker I'm a roller skater / blader
 I'm a scooter rider I'm a parent / guardian or spectator
 Other (please specify) _____

2. How would you describe your skateboarding / riding ability?

- Beginner Intermediate Advanced I don't skate or ride

3. How often do you skate / ride?

- 3+ days a week 1-2 times a week 1-2 times a month I don't skate or ride

4. What part of the All Wheel Park interests you the most?

- Pump Track Skatepark

5. What's your favourite PUMP TRACK option, and why? Option #1 Option #2 Option #3

6. What's your favourite SKATEPARK option, and why? Option #1 Option #2 Option #3

7. Beyond the Pump Track and Skatepark facilities themselves, is there anything else you would like to see in the park? (i.e. seating / viewing spaces, landscaping, shade, washrooms, etc.)

seating

8. General Comments. (use the adjacent box or back of this sheet if you need more space)

so cool great ideas

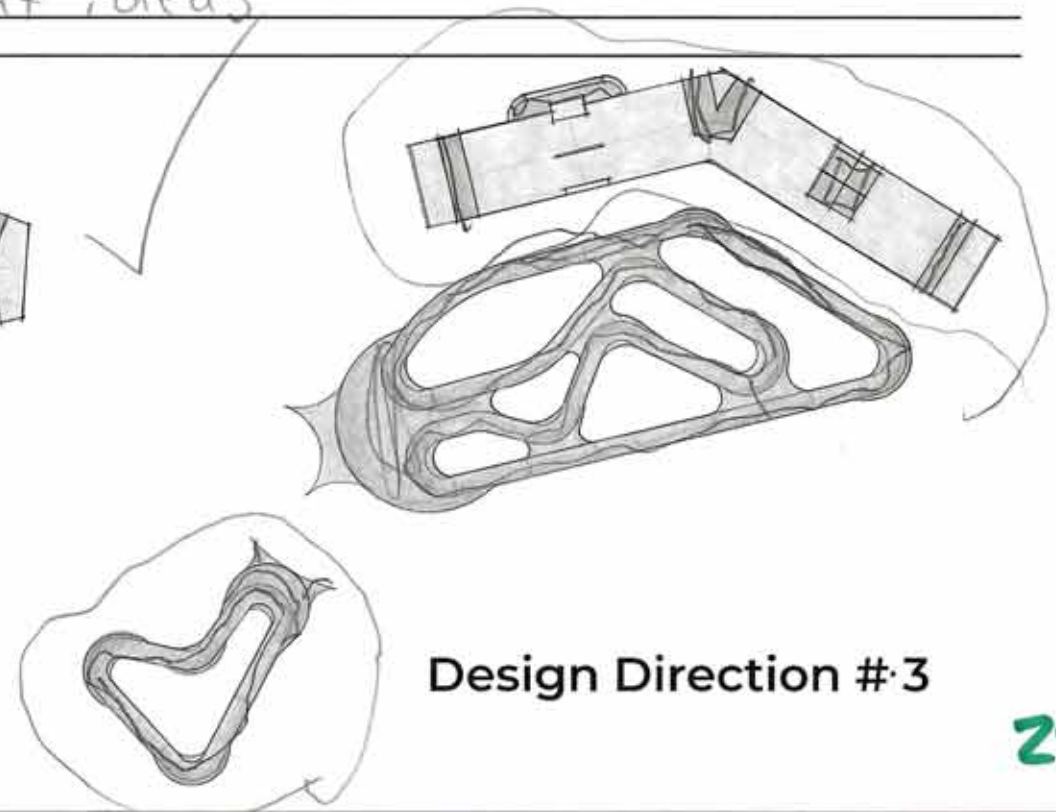
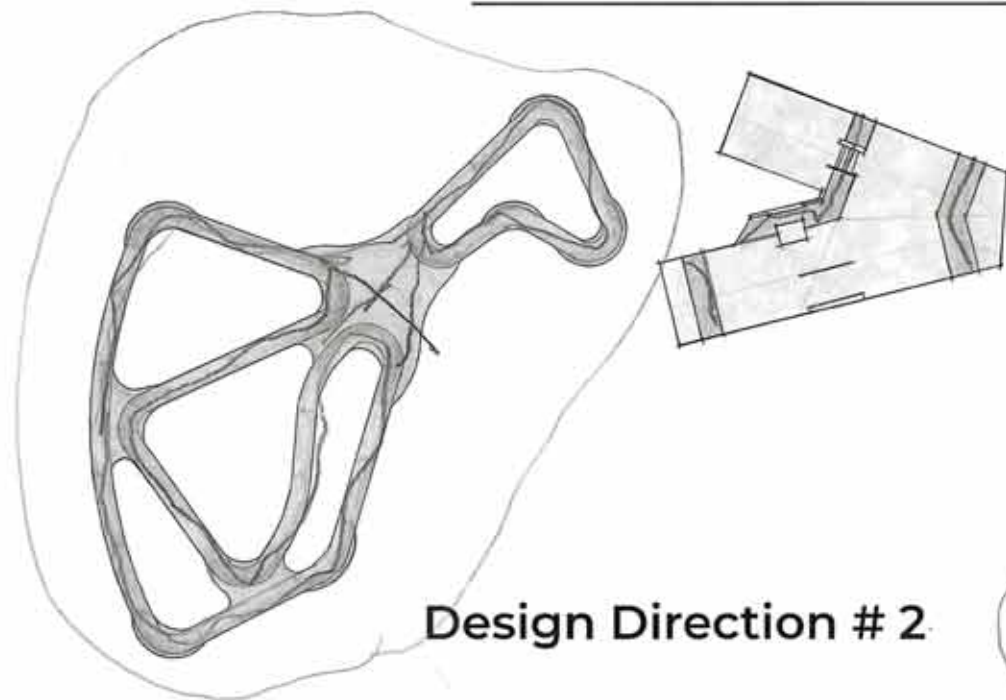
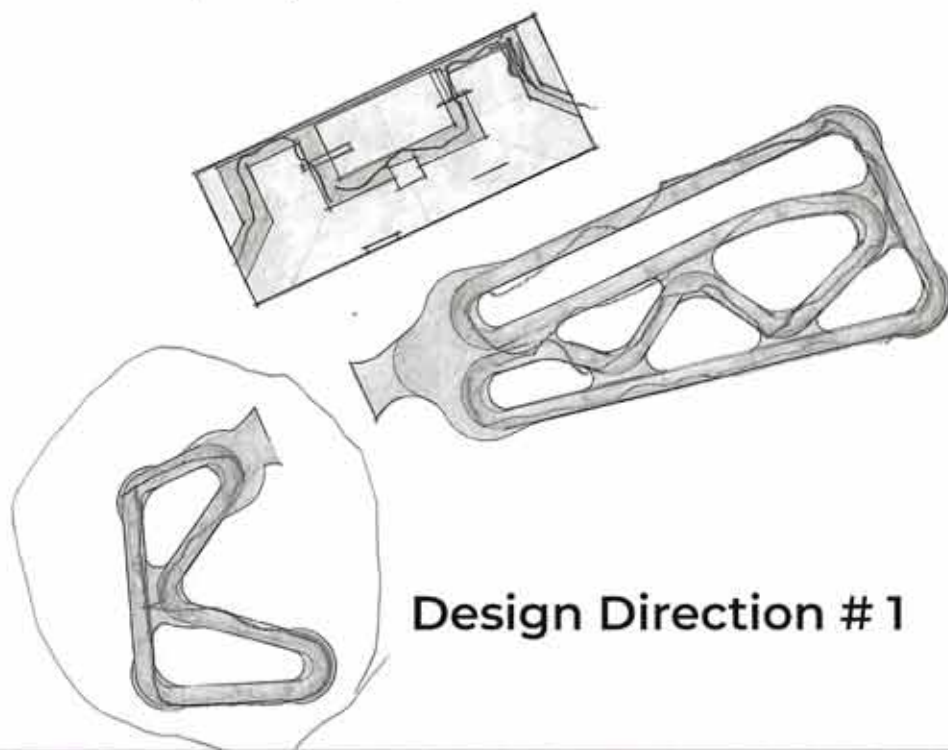

25



23

KIWANIS ALL WHEEL PARK

WORKSHOP FEEDBACK FORM

Name: [REDACTED] Age: _____

Email: [REDACTED]

1. What is your primary interest in this project?

- I'm a skateboarder
 I'm a BMX rider
 I'm a mountain biker
 I'm a roller skater / blader
 I'm a scooter rider
 I'm a parent / guardian or spectator
 Other (please specify) _____

2. How would you describe your skateboarding / riding ability?

- Beginner
 Intermediate
 Advanced
 I don't skate or ride

3. How often do you skate / ride?

- 3+ days a week
 1-2 times a week
 1-2 times a month
 I don't skate or ride

4. What part of the All Wheel Park interests you the most?

- Pump Track
 Skatepark

5. What's your favourite PUMP TRACK option, and why?
 Option #1
 Option #2
 Option #3

I prefer: Junior Track #1
 Advanced Track #3

6. What's your favourite SKATEPARK option, and why?
 Option #1
 Option #2
 Option #3

7. Beyond the Pump Track and Skatepark facilities themselves, is there anything else you would like to see in the park?
 (i.e. seating / viewing spaces, landscaping, shade, washrooms, etc.)

8 washrooms

8. General Comments. (use the adjacent box or back of this sheet if you need more space)

Happy to see a 'New Line' 'Velo Selections' Collaboration!

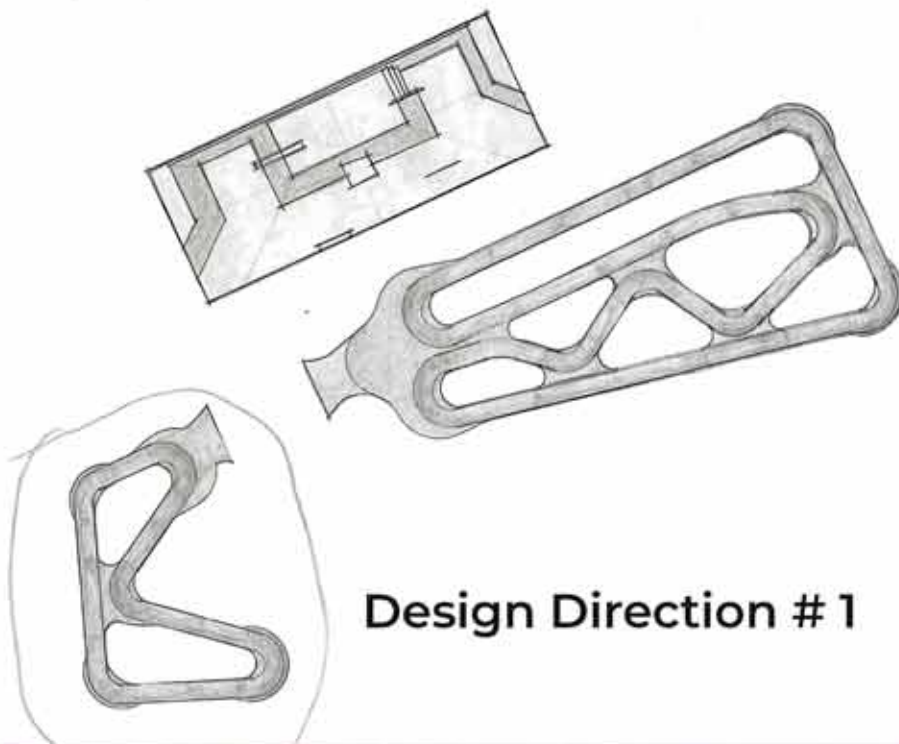

Design Direction # 1

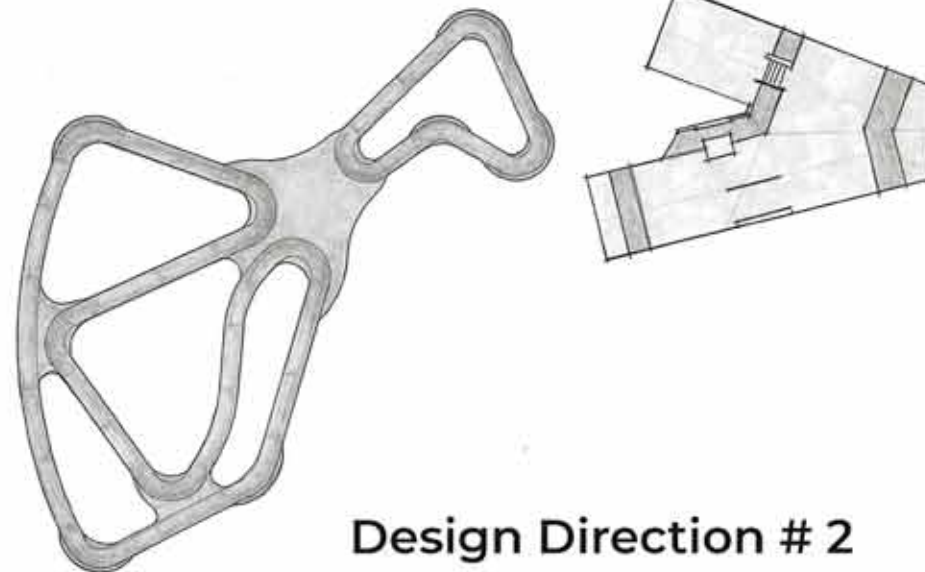

Design Direction # 2

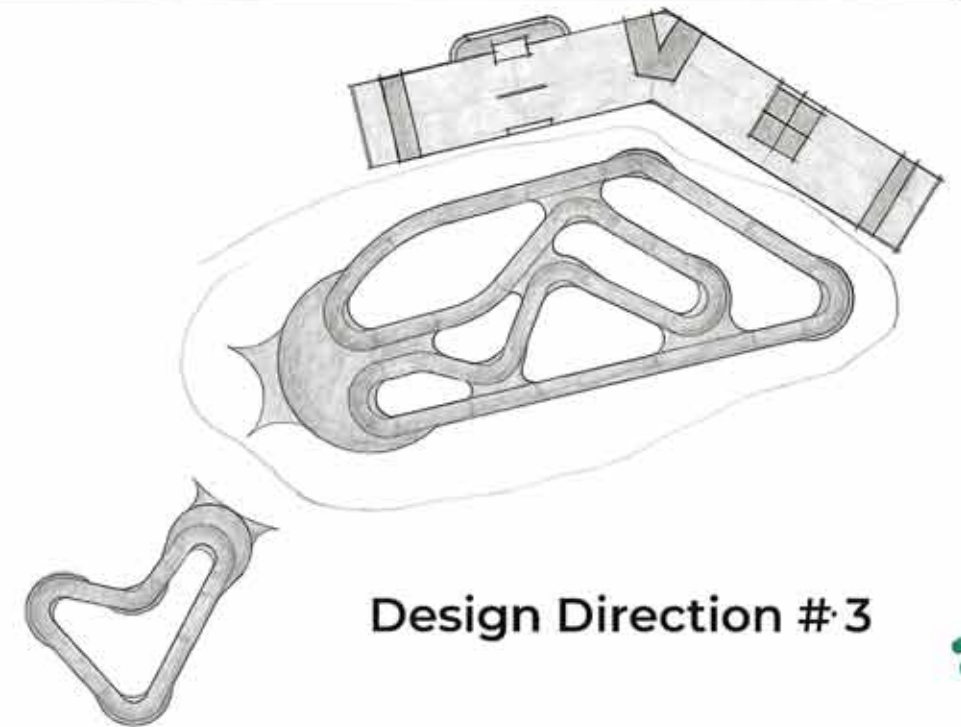

Design Direction # 3

26

KIWANIS ALL WHEEL PARK

WORKSHOP FEEDBACK FORM

Name: [Redacted] Age: 7

Parent Email: [Redacted]

1. What is your primary interest in this project?

- I'm a skateboarder I'm a BMX rider I'm a mountain biker I'm a roller skater / blader
 I'm a scooter rider I'm a parent / guardian or spectator
 Other (please specify) _____

2. How would you describe your skateboarding / riding ability?

- Beginner Intermediate Advanced I don't skate or ride

3. How often do you skate / ride?

- 3+ days a week 1-2 times a week 1-2 times a month I don't skate or ride

4. What part of the All Wheel Park interests you the most?

- Pump Track Skatepark

5. What's your favourite PUMP TRACK option, and why? Option #1 Option #2 Option #3

6. What's your favourite SKATEPARK option, and why? Option #1 Option #2 Option #3

7. Beyond the Pump Track and Skatepark facilities themselves, is there anything else you would like to see in the park?
(i.e. seating / viewing spaces, landscaping, shade, washrooms, etc.)

Trees

8. General Comments. (use the adjacent box or back of this sheet if you need more space)

cool

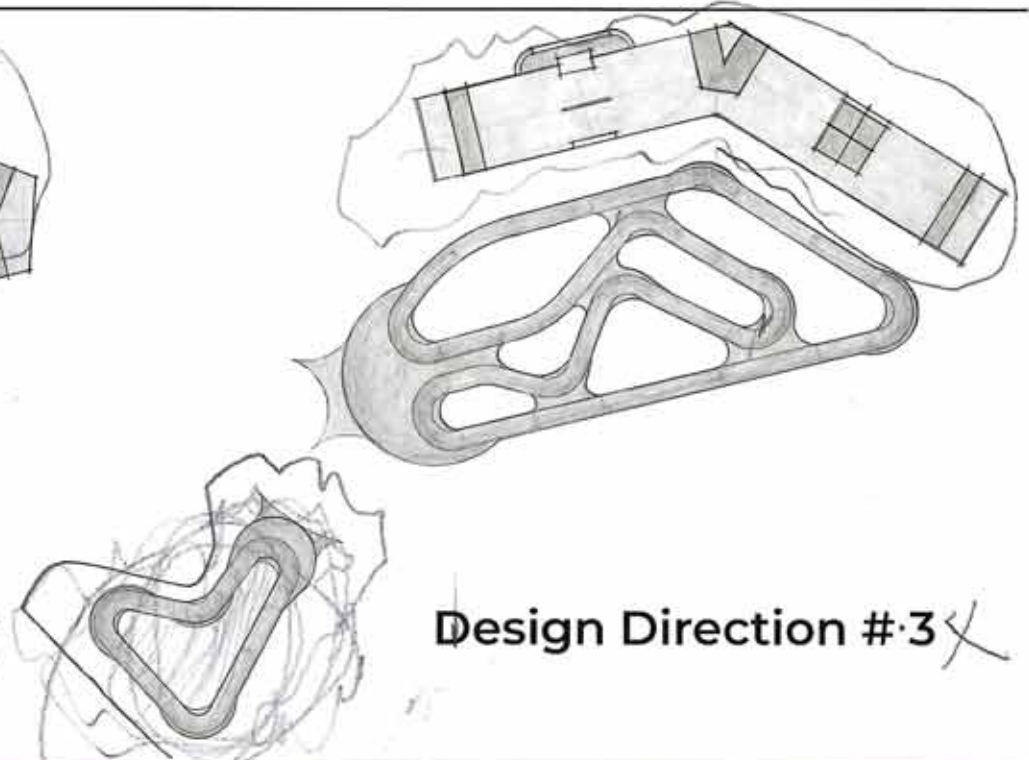
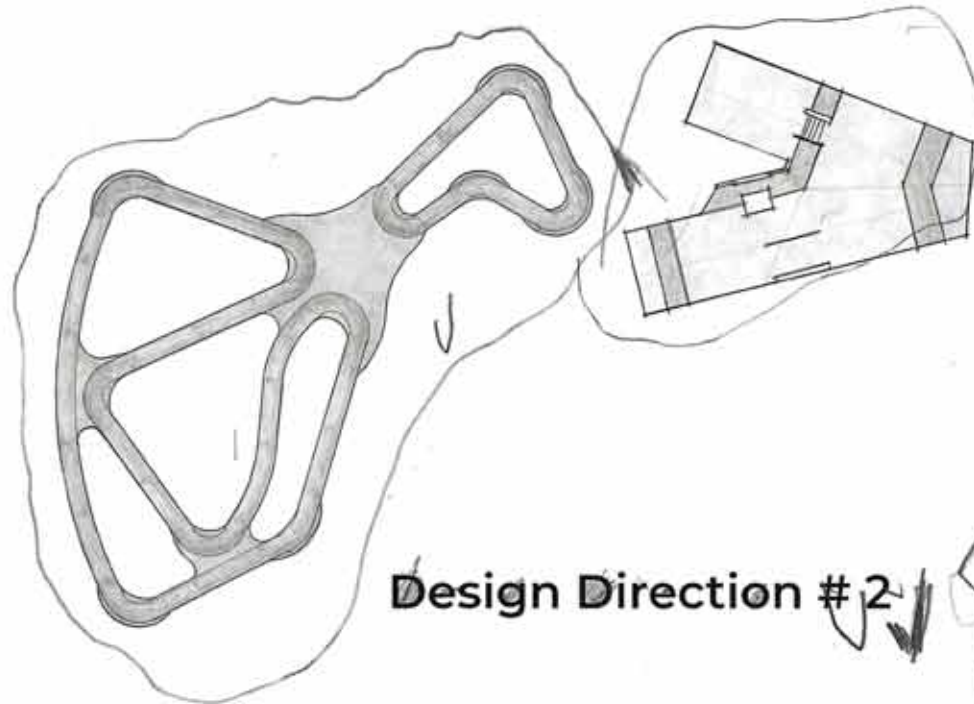
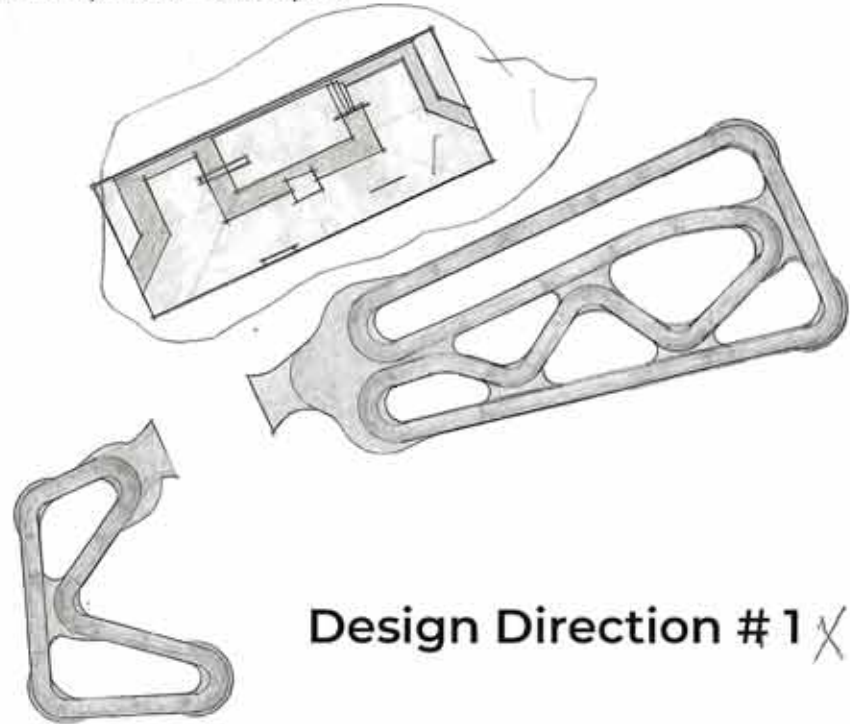

27

KIWANIS ALL WHEEL PARK

WORKSHOP FEEDBACK FORM

Name: [REDACTED] Age: 28

Email: [REDACTED]

1. What is your primary interest in this project?

- I'm a skateboarder
 I'm a BMX rider
 I'm a mountain biker
 I'm a roller skater / blader
 I'm a scooter rider
 I'm a parent / guardian or spectator
 Other (please specify) _____

2. How would you describe your skateboarding / riding ability?

- Beginner
 Intermediate
 Advanced
 I don't skate or ride

3. How often do you skate / ride?

- 3+ days a week
 1-2 times a week
 1-2 times a month
 I don't skate or ride

4. What part of the All Wheel Park interests you the most?

- Pump Track
 Skatepark

5. What's your favourite PUMP TRACK option, and why? Option #1 Option #2 Option #3

Between 2 and 3
I like how #2 flows both together better one to the next
But probably like the layout of #3 better

6. What's your favourite SKATEPARK option, and why? Option #1 Option #2 Option #3

again combo of #1 and #3 I like size and layout of #3
however I would love to see a stair with rail and ledge feature

7. Beyond the Pump Track and Skatepark facilities themselves, is there anything else you would like to see in the park?
(i.e. seating / viewing spaces, landscaping, shade, washrooms, etc.)

a shade area is always great at a park and also a fountain
at the washroom would be great

8. General Comments. (use the adjacent box or back of this sheet if you need more space)

Not against pump tracks, very stoked to ride it however in my experience generally the pump track is minimally used so I would
presumably like to see maybe some junior features in the large pump track
and a larger skatepark or at least another location

